

Mechanical Drawing Principles

Work Procedure W009

Revision 10, March 9, 2014

General:

This document provides the mechanical drawing basic principles and best practice for creating and editing mechanical drawings in Ziv-Av Engineering. This document is based on SII (Israeli standards) and ISO drawing standards. The goal of this document is to supply tools to enable the creating of well made drawings. This document applies to both English based and Hebrew based drawings.

This document is obligatory, unless there is a different requirement from the customer.

Revision	Description	Edited	Approved	Date
9	Overall modifications	Eti Ben Simhon	Ofer Rotem	14.2.13
10	Clauses 5.4, 10.2.13, 11 were modified	Eti Ben Simhon	Ofer Rotem	9.3.14

Contents

1. Drawing format	4
2. Projection views method.	8
3. Projections order on the drawing sheet.....	10
4. Drawing Scale	12
5. Line types	14
6. Section views.....	16
7. Common Section Views	19
8. Auxiliary View And Detail View.....	23
9. Thread Marking	24
10. Dimensioning	24
11. Drawings of parts with fasteners.....	48
12. Welds drawings.....	52
13. Assembly drawing.....	54
14. Revision table (ECO)	55
15. Dimensioning methods	56
16. Dimension tolerances	57
17. Geometric tolerances.....	57
18. Surface finish.....	57
19. Weld symbols.....	58
20. Drawing configuration check-list.....	58

1. Drawing format

All Ziv-Av drawings will be made on A3 sheet size format, unless there is a different requirement from the customer. When there is a need for a multi-view drawing, additional A3 sheets may be added.

1.1. Ziv-Av has the following drawing templates, each one specific for a different manufacturing process:

Sheet format name	Description (manufacturing type)
A3 - Framing - Sheet1	Frame structures - Steel profiles, pipes, flame cut steels.
A3 - Machining - Sheet1	Machining (metals and plastics)
A3 - Plastic - Sheet1	Plastic injection molding
A3 - SheetMetal - Sheet1	Flat or bend laser cut sheet metals
A3 - Welding - Sheet1	Welding assemblies
A3 - Wiring - Sheet1	Wiring
A3 - Assembly - Sheet1	Mechanical assemblies
A3 - Sheet2	2 nd sheet of drawing (for all formats)

Typical Ziv-Av sheet format example is followed:

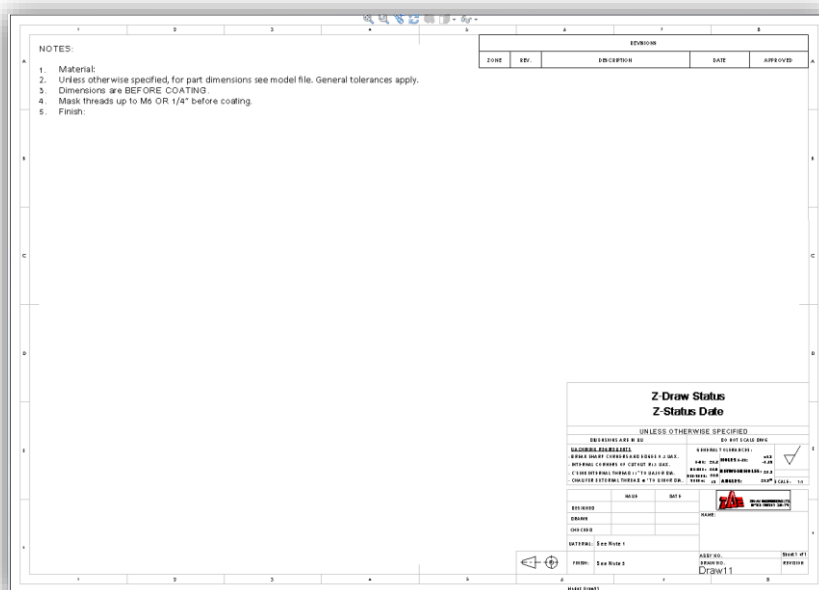

The image shows a typical Ziv-Av drawing sheet format. It includes a 'NOTES' section with five points: 1. Material; 2. Unless otherwise specified, for part dimensions see model file. General tolerances apply; 3. Dimensions are BEFORE COATING; 4. Mask threads up to M6 OR 1/4" before coating; 5. Finish. There is a revision table with columns for 'DATE', 'REV.', 'DESCRIPTION', 'DATE', and 'APPROVED'. At the bottom right, there is a 'Z-Draw Status' section with 'Z-Status Date' and a table for 'UNLESS OTHERWISE SPECIFIED' with columns for 'DESCRIPTION', 'DATE', 'BY', and 'CHECKED'. The drawing area is mostly blank, with a grid and a title block at the bottom right.

1.2. There are three SolidWorks file formats in Ziv-Av:

Part, Assembly and the Drawing formats introduced in paragraph 1.1.

1.3. Custom properties:

All the drawing details (such as material, description etc.) will be inserted as "Custom Properties" in the **model** file, except two: Material & Finish. These are added to the drawing file custom properties.

Both Part file and Assembly file have 21 Custom properties. These properties must be present in any file, even if left blank.

Ziv-av developed an external application named "Custom Property Builder" that enables custom property filling:

To start using the "Custom Property Builder" go to "ZAE_Env" folder on your computer desktop and double click the "Custom Property Builder" file.

When using the EPDM software and manually updating the model properties, the model card will have all the required properties fields, and you need to fill them.

Following is the complete "Custom properties" list that should be in all model files (Parts and Assemblies):

	Property Name	Type	Value / Text Expression	Evaluated Value
1	Designed_Name	Text	XX-ZA	XX-ZA
2	Checked_Name	Text	XX-ZA	XX-ZA
3	Drawn_Name	Text	XX-ZA	XX-ZA
4	Description	Text		
5	Revision	Text	0	0
6	Designed_Date	Date	14/01/2013	14/01/2013
7	Drawn_Date	Date	14/01/2013	14/01/2013
8	Checked_Date	Date	14/01/2013	14/01/2013
9	Machine_Level	Text		
10	Mass	Text	"SW-Mass@Qylur Part.sldprt"	0.00
11	Material	Text	"SW-Material@Qylur Part.sldprt"	Material <not specified>
12	Finish	Text		
13	Z-Technology	Text	Sheetmetal Machining Welding	Sheetmetal Machining Welding
14	Z-Finish Type	Text	Coating Painting	Coating Painting
15	Z-Critical Part	Text	Yes No	Yes No
16	Z-Part Status	Text	Make Buy	Make Buy
17	Vendor Name	Text		
18	Vendor PartNo	Text		
19	PartNo	Text	\$PRP:"SW-File Name"	Qylur Part
20	Project Name	Text		
21	IsFastener	Text	0 1	0 1

"Machine-Level" - Line 9:

Surface finish size. For example: N7. For Sheet Metals this property should be left blank.

"Z-Part-Status" - Line 16:

When the part is a purchased part, keep the "Buy" value. When you fill the properties using the EPDM software, only the required properties for "Buy" part will remain active. When you use the "Custom Property Builder" software, you should only fill the following properties:

Property Name	Type	Value / Text Expression	Evaluated Value
Description	Text		
Mass	Text	"SW-Mass@Part1.sldprt"	0.00
Material	Text	"SW-Material@Part1.sldprt"	Material <not specified>
Z-Part Status	Text	Buy	Buy
Vendor Name	Text		
PartNo	Text	\$PRP:"SW-File Name"	Part1
Vendor PartNo	Text		
IsFastener	Text	0 1	0 1

"IsFastener" - Line 21:

When the part is a fastener, keep the property value "1".

When the part is an Off-the-Shelf part or a manufactured part, keep the property value "0".

Names and dates format

Names: Full first name, space, first letter of the family name, dot, "-ZAE". For example: Benny R. - ZAE

Date: dd/mm/yyyy. For example: 19/08/2011

"Description" format

Capital letter at the sentence beginning.

"Material" and "Finish" details

In the title block notes will direct to the "Notes" area:

- MATERIAL: See Note 1
- FINISH: See Note 5

When there is no Material or finish in the part, write "None" instead.

The drawing files formats have the following custom properties:

	Property Name	Type	Value / Text	Evaluated Value
1	Z-Draw Status	Text	Z-Draw Status	Z-Draw Status
2	Z-Status Date	Text	Z-Status Date	Z-Status Date
3				

Both of these properties will be automatically filled by the EPDM in the drawing approval process.

Z-Draw Status is one of three possible approval stamps:

- Approved for Quotation
- Approved for Prototype Production
- Approved for Production

Z-Status Date is the approval date.

2. Projection views method.

There are two ways to create drawing projection views:

- European ISO - First angle Projection
- US ANSI - Third Angle Projection

In the next sketch there is a cross of planes that creates the four quarters:

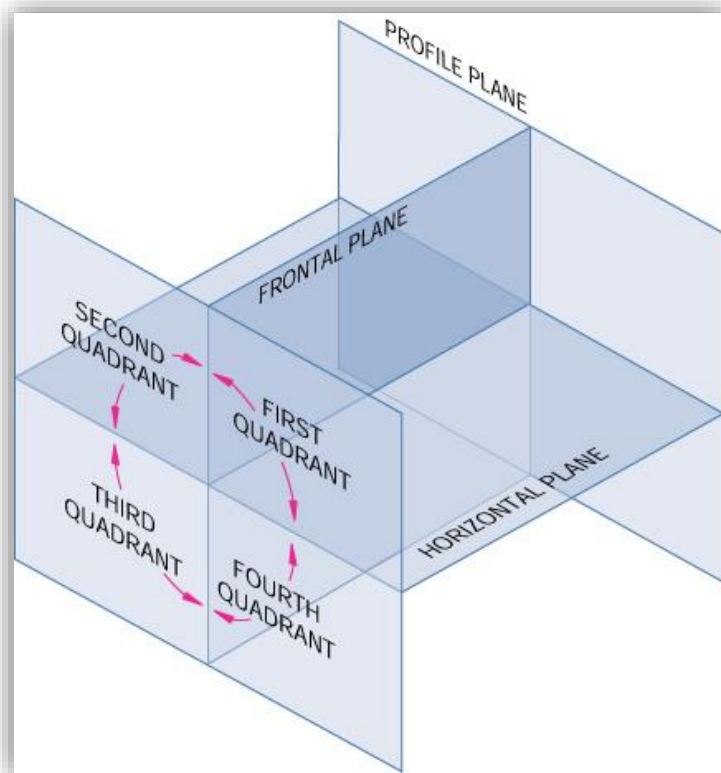

In the next sketch, the projection of the 1st and 3rd quarters is visible:

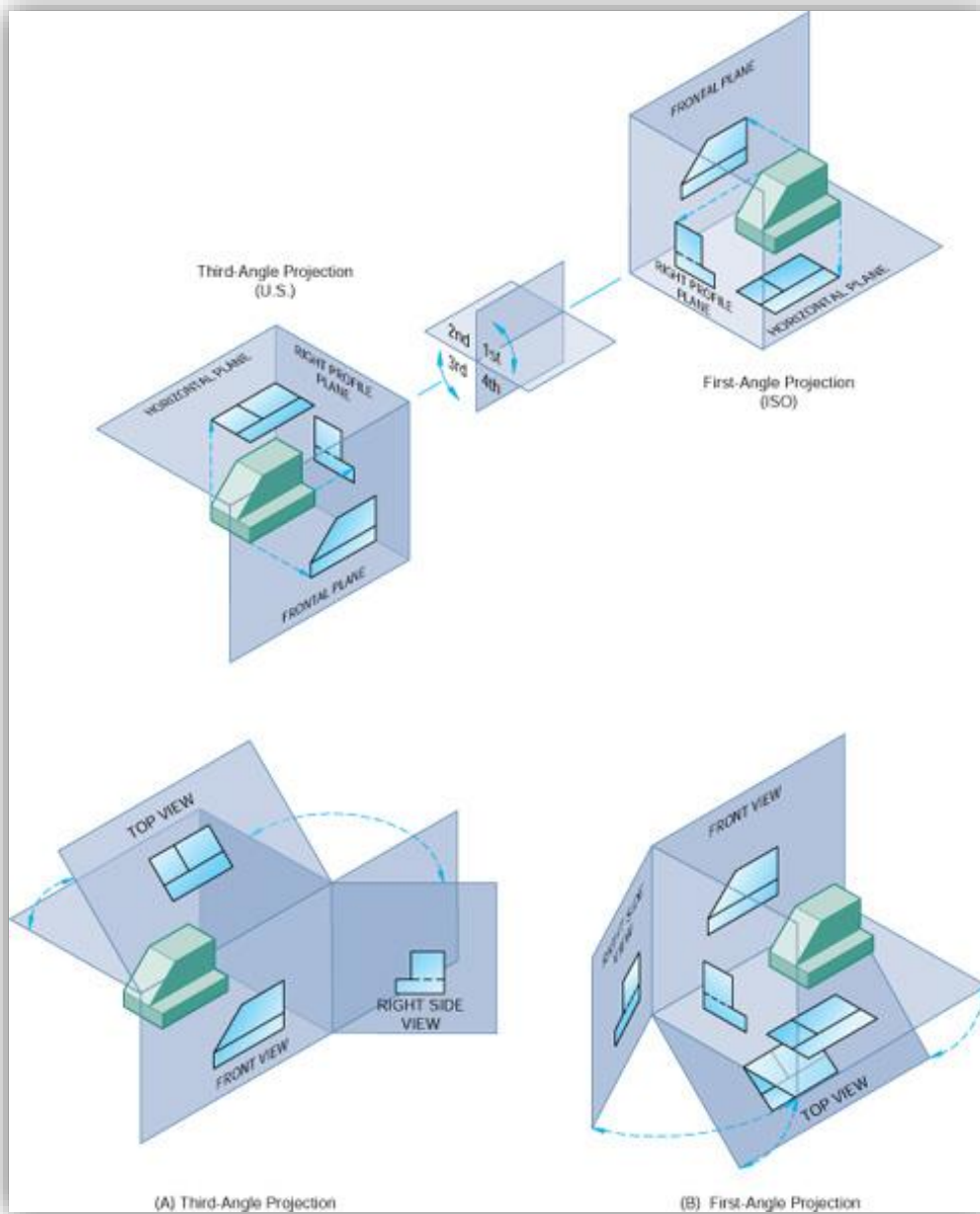

Additional explanation for the views projections is given in the next sketch. On the right side there is the European Projection, and on the left- the US projection.

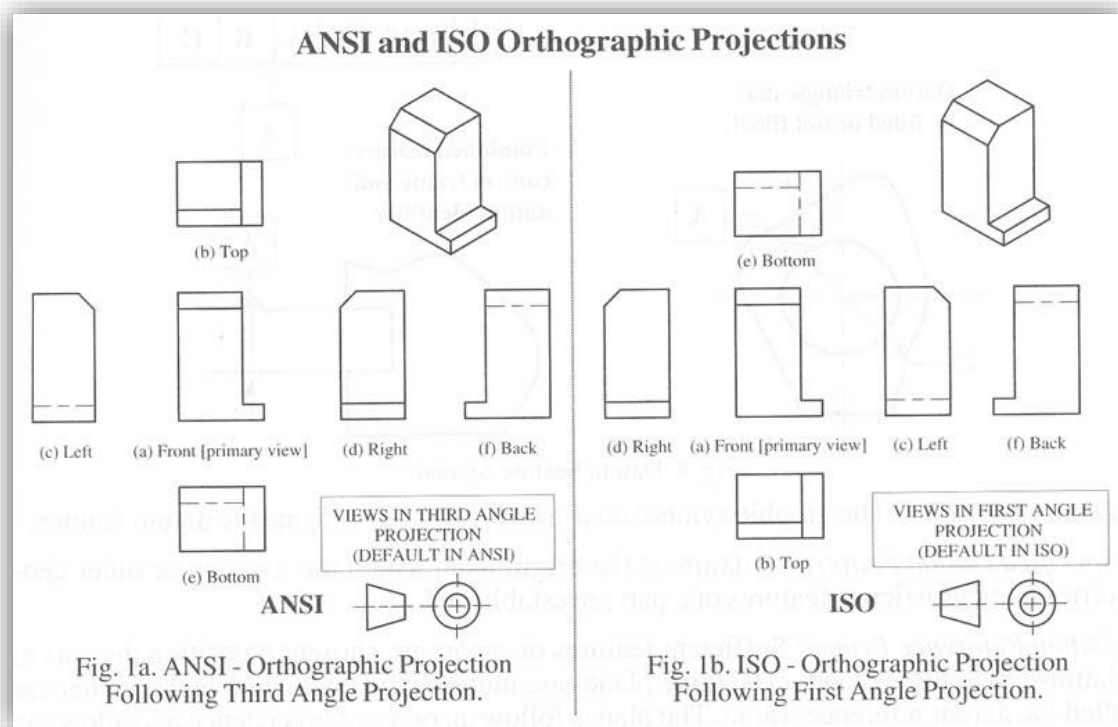

Ziv-Av Engineering uses the European projection system, 1st Angle Projection (According to the Israeli standards and ISO standards), as shown on the right side. On the drawing template appears the following sketch:

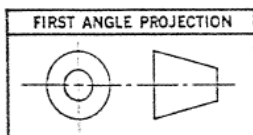

3. Projections order on the drawing sheet

- 3.1. The minimum required projection views (and section views) for proper part manufacturing or for correct assembly will be displayed on the drawing sheet (the minimum views that are required for full understanding of the part or assembly).
- 3.2. The principal view is the view with the most part information (which is not necessarily the "Front view" as was built in the model).
- 3.3. All the views on the sheet must be related. Each view is projected from another view. A view cannot be positioned randomly on the drawing sheet.

- 3.4. A projected view that is positioned on the next drawing sheet must have a name (VIEW X) and an arrow needs to be added from the view it was projected from on the first sheet.
- 3.5. All views must be spaced equally.
- 3.6. All views on the drawing must have at least one dimension associated to them (except for isometric view).
- 3.7. A part will be drawn positioned in such a way so the part main surface is horizontal, and not as it was built in the model (where a part can be built in an angle).
- 3.8. Isometric View
- 3.8.1. The isometric view projection angle will be compatible with the principle view projection angle.

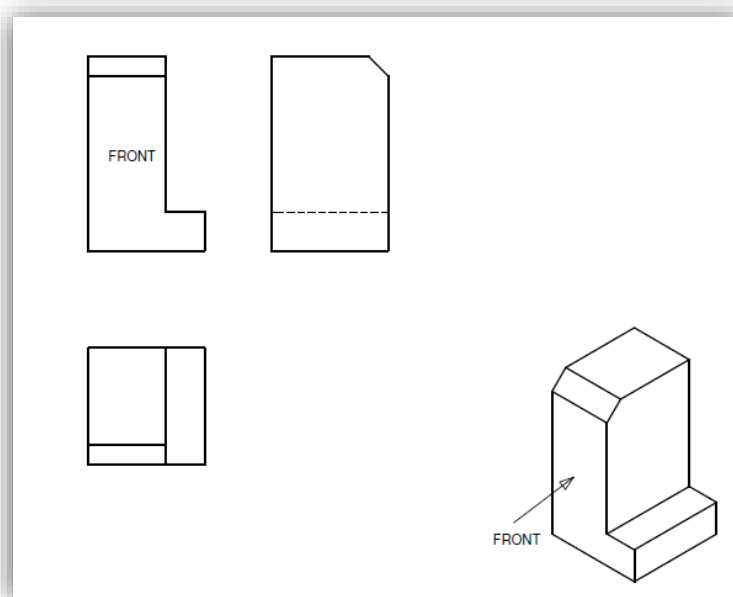

- 3.8.2. It is possible to add more isometric views from additional angles of the part, in order to show details. The additional views need to be annotated as "ISO Rotated".
- 3.8.3. Flat sheetmetal parts do not need isometric view.

4. Drawing Scale

4.1. Standards Scale

Whenever possible, the drawing should present the part in true scale (scale 1:1), otherwise standard scale is to be selected from the table below:

Scale down	Scale up
1:2	2:1
1:2.5	5:1
1:5	10:1
1:10	

If there is a need for a larger or smaller scale, use the above scale with a factor of ten.

4.2. Scaled up drawings

4.2.1. A part should not be scaled up to the sheet width, but up to a level in which the dimensions will be clearly applied.

4.2.2. When a very small part is scaled up to a very large scale because of its details, **additional view (not isometric one) in 1:1 scale** should be added, in order to give the manufacture a true proportion of the part (see example below).

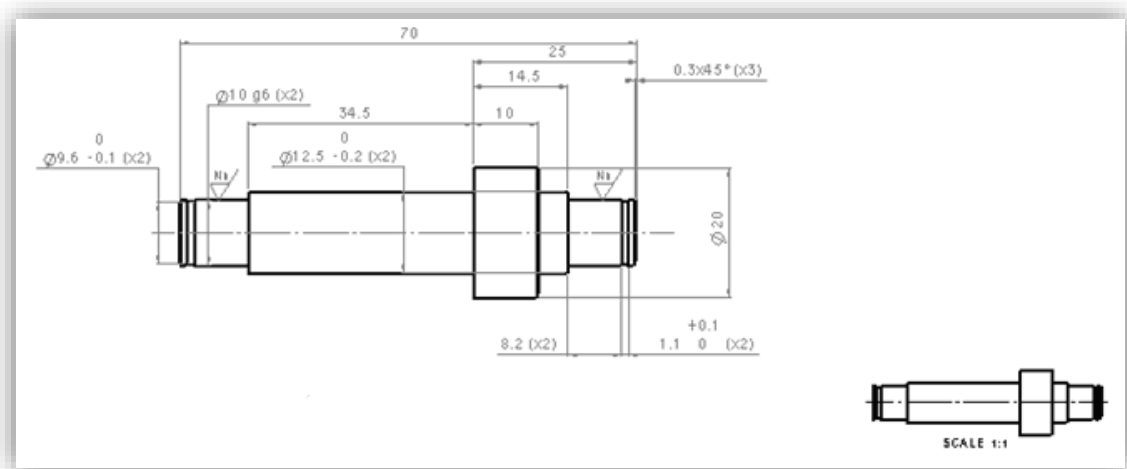

4.3. Scale annotation

Each drawing has its default scale that is notated in the drawing Title block. Each view that has a different scale (scaled up or scaled down) will be notated underneath as following:

Section A-A	View A	Detail A
Scale 2:1	Scale 1:2	Scale 1:1

4.4. Break lines in views

Long parts (such as profiles, pipes, and flat sheetmetals) should be drawn only with the required details to fully define the part. An appropriate scale should be used and break lines will be added along its long feature, so the part will fit the drawing sheet.

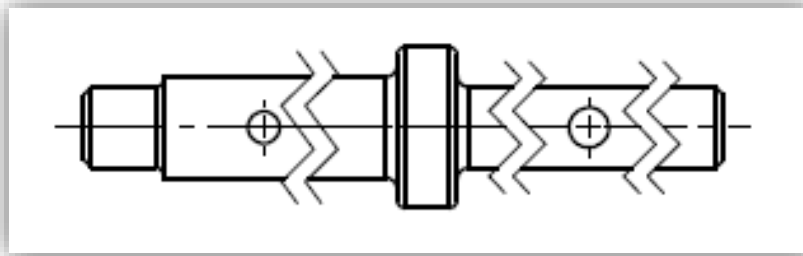

Always double check for details that have been lost because of the break lines, including holes and other features (see below for explanation).

When a part model, with a break lines in his drawing, is being updated, one must go back to the drawing, undo the break lines, and recheck that all the required information is visible, and nothing is cut away. If some data is being cut away, the break lines should be adjusted so all the information is visible again.

5. Line types

5.1. Hidden lines

The use of hidden lines should be avoided in drawing views.

5.2. Tangent lines

5.2.1. Tangent lines should be visible only in isometric view, and with the use of a thin line.

5.2.2. Projected view of sheetmetal part that has a bending angle which is different than 90° - the tangent lines should be shown.

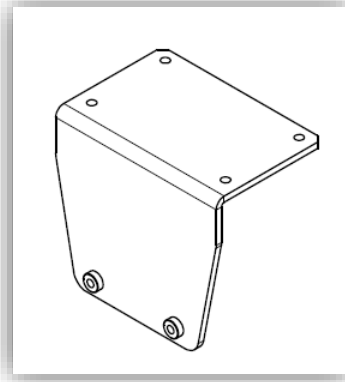

Isometric view

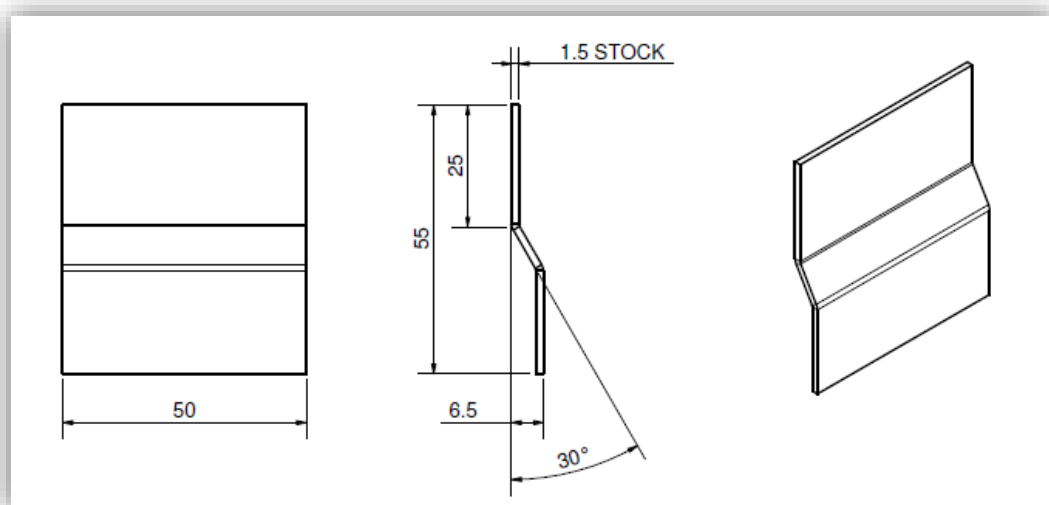

Bent Sheetmetal

5.3. Axis lines

5.3.1. On views of lathed parts \ pipes \ bars, an axis line should be added. One shouldn't use the "Center Line" mark in these cases.

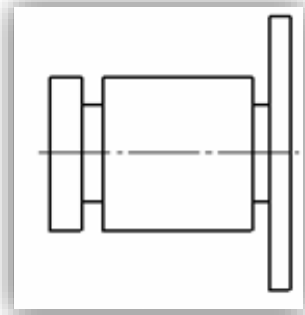

5.3.2. For parts with drills (holes or threads), an axis line should be added to the drill feature center. When using a very small scale and the drills become diminutive, one shouldn't draw axis lines so as not to hide the drill features.

5.3.3. For a reduced dimensions drawing of a sheetmetal part that has many drills, the axis lines can be drawn only for the drills which are dimensioned.

5.4. Symmetry lines

Symmetrical parts (excluding lathed parts \ pipes \ bars that should be drawn according to section 5.3.2) will be marked with a symmetry line in the center of the part with "CL" mark attached. Symmetry lines are per view and not per part, meaning, each view has its own symmetry lines. If the part is symmetrical in both axis "X" and "Y", two symmetry lines should be drawn with "CL" mark attached to each of them.

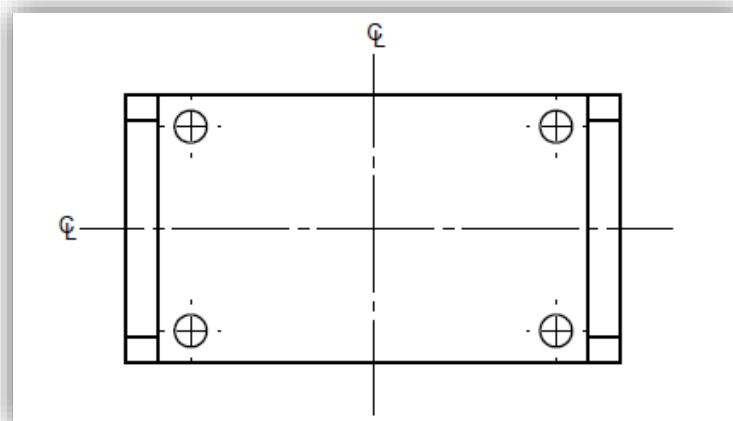

5.5. Flat surface mark

In order to save the need for additional views, it is a common practice to mark flat planes located on round objects with two diagonal crossing lines. The lines should be continuous, thin lines as shown below:

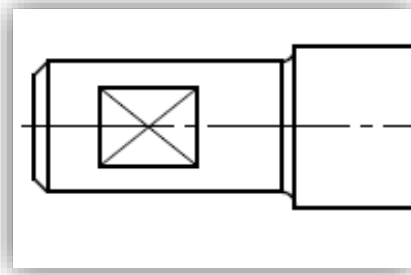

6. Section views

6.1. Section view is created by cutting the part and removing the cut area in order to show form and structure of the cut plane.

6.2. One should not make a section view out of an existing section view!

6.3. Cut position: The cut is positioned in line with the arrows that show the section view line and the projection direction. When one needs to rotate (to align) the section view, the rotation angle needs to be annotated below the section view label. For instant, if one rotated the section view 45° , view should be annotated "ROTATED 45° ".

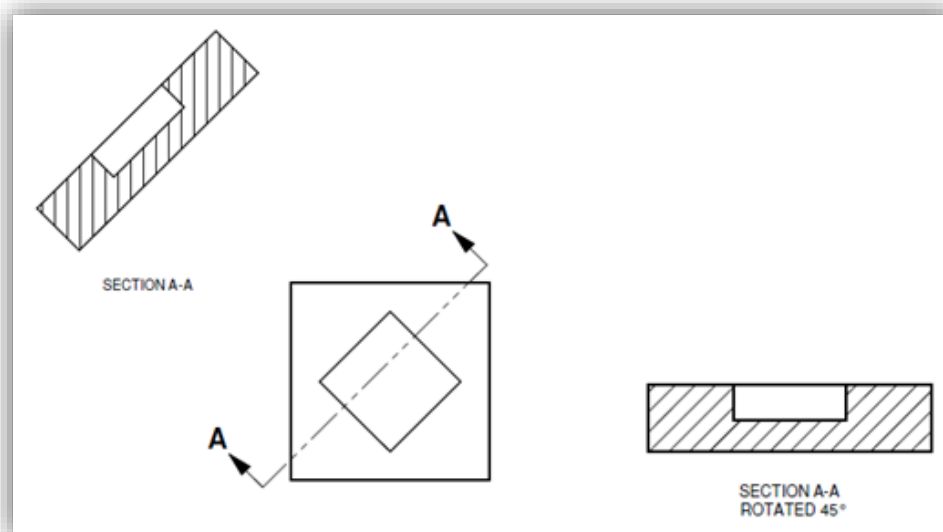

6.4. The section views should appear on the same drawing sheet with the section origin view. In case that the drawing sheet is too loaded, and there are many section views, it is common practice to move the section views to the next sheet.

An annotation should be added next to the section view label as follows:

"See sheet 2 (A6)", A6 being the section view area on sheet 2.

On sheet 2, under the section view name, the following note should be added:

"See sheet 1 (C3)", C3 being the section view letter label on sheet 1.

Needless to say that if required, more than one sheet can be added, but they all should follow the annotation rules that were presented above.

The section view on sheet 2 should be positioned in the same orientation as if it was in the same sheet with the section origin view.

6.5. Labeling

6.5.1. Views / section views are labeled with capital letters. The labeling will start with "A" and will continue alphabetically. One should not start the labeling randomly.

6.5.2. The following letters are excluded from the labeling list: "I", "J", "O", "Q".

6.5.3. After reaching the letter "Z", the labeling will continued with "AA", "AB" and so on.

6.5.4. A letter should not be used more than once after it was given to a view / section view.

6.5.5. Datum feature symbols for geometric tolerances marking will always start with the letter "A", even if there is a use of that letter in the views labeling as well (the two are not related).

6.5.6. Capital letters should be used for the labeling of sections, views, details, repeating details, annotations and as a general use rule (SECTION A-A, DETAIL B, TYP. 2 PLACES).

6.5.7. Area fill (hatch) lines

6.5.7.1. Area fill lines should always be drawn at an angle to the part body lines in the cut area (in practice, a 45° angle is the common angle):

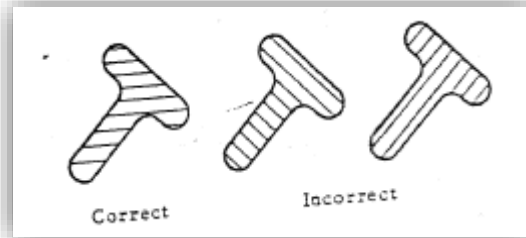

6.5.7.2. If there are different parts cut in the same area, one should use different line angles for each of the parts, in order to distinguish between the parts:

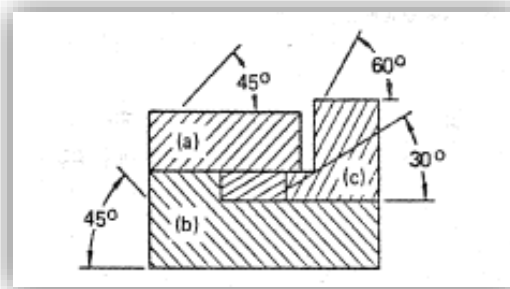

6.5.7.3. Hinges, nuts, bolts, bars, rivets, keys, pins and similar parts (parts without holes) that their main axis is on the same plane as the cut section plane, should not be cut in the cut section view:

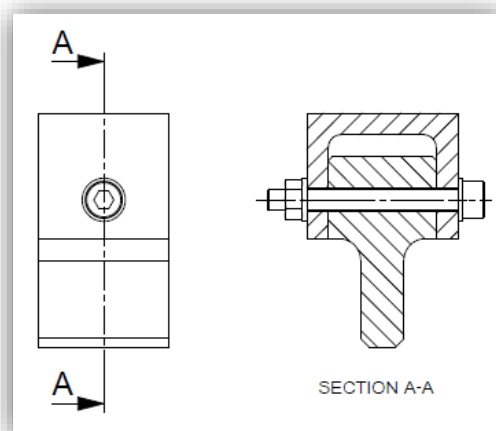

6.5.7.4. The letters labeling the cut plane should not cross body lines or dimensions.

7. Common Section Views

7.1. Full section view

Full section view is achieved when the cut plane divides the whole part.

7.2. Aligned section view

- When an aligned section view is made, the line that connect two different planes must be drawn through solid material (the line must not go through hollowed area like drill hole, but outskirt it).
- The aligned section view must not have lines indicating where the planes changed (the section view should be continuous). The plane changed indication lines sometimes are drawn automatically in SolidWorks, so the "hide" feature should be applied to them.

See example below:

Changing cut plane thru solid body

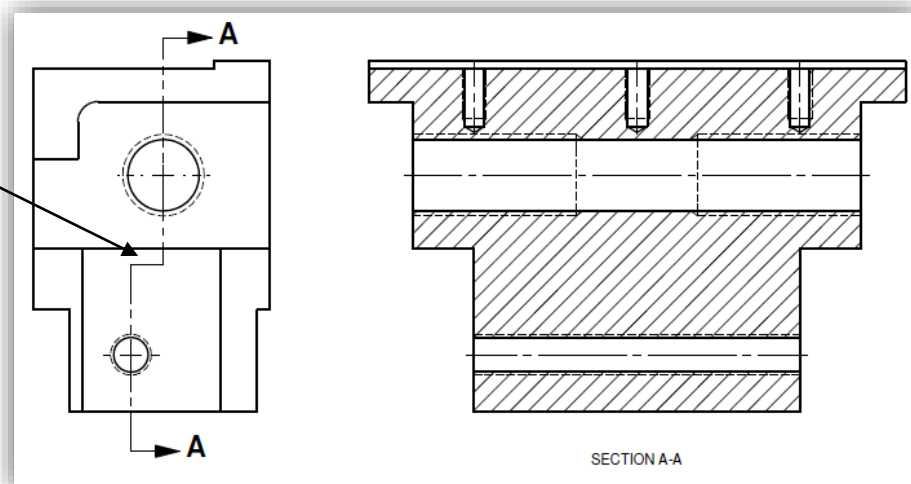

7.3. Half section

Half section is usually used for symmetrical parts. The line that connects the full view and the half section view will be the symmetry line and not a body line. Hidden lines should not be used in half section views. There is no need to mark the cut line, and there is no need to label the view. The given dimensions should be divided into two groups: External dimensions in the full view area and internal dimensions in the half section view area (refer to section 7.5 for details on how to create broken-out section view).

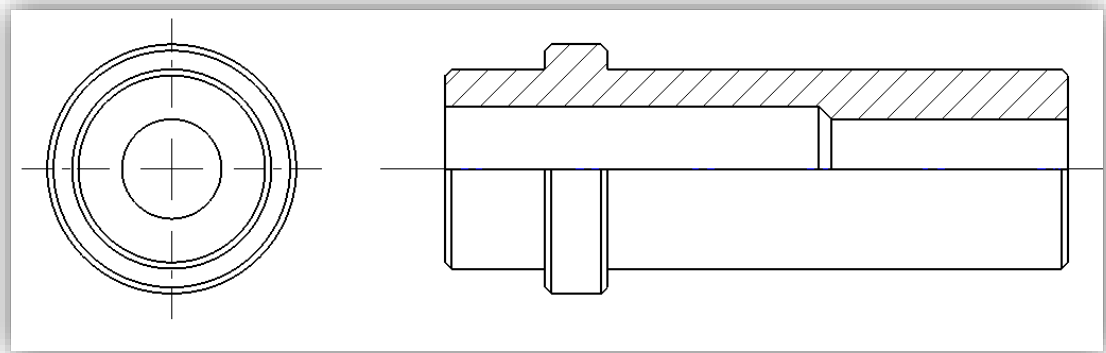

7.4. Full section as the only view in the drawing

If the drawn parts are simple round ones, like a bushing or a disk, one can use the full section view as the single view of the part, without the need for the section source view or the need to label the section view (refer to section 7.5 for details on how to create broken-out section view).

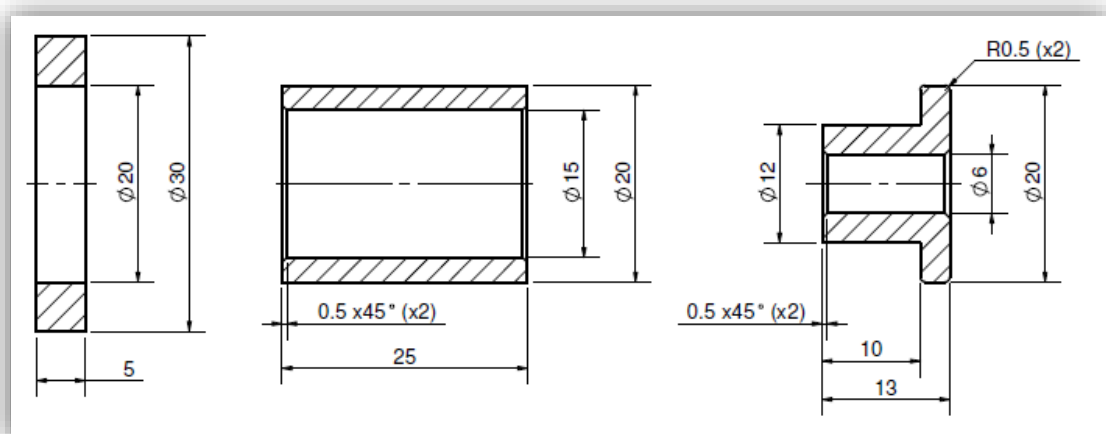

7.5. Broken-out section

Broken-out section is made when there is no reason to make a full body section but there are some features that can be missed without the use of cut sections. Usually the use of broken-out section is when the part is a large one, and there is a rather small detail in it which needs to be shown.

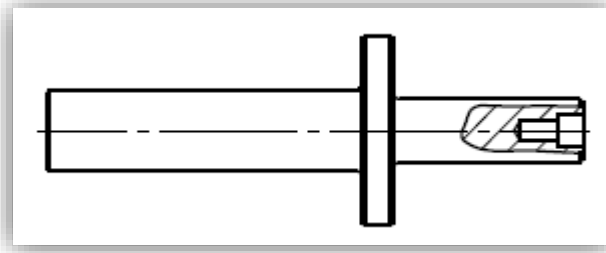

Example 1

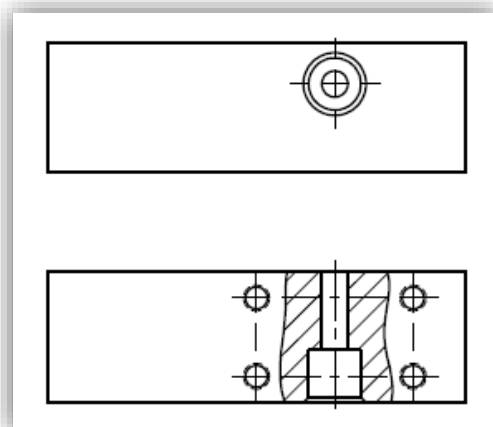

Example 2

In the next example there is a turned part. To create the cut section the part true axis is added in the part model:

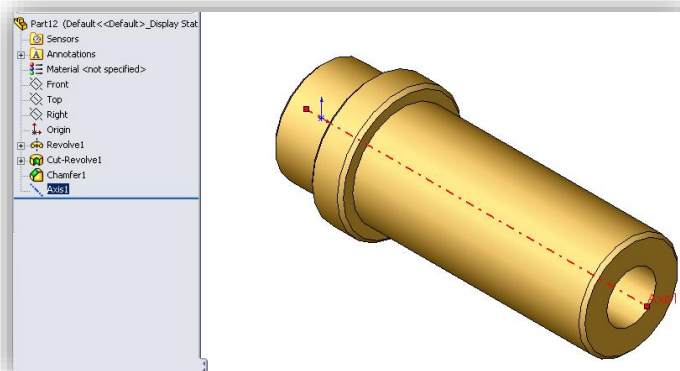

A full side view is added to the drawing. For half view one needs to add rectangle on the axis line. For full section view the rectangle needs to circle the whole body:

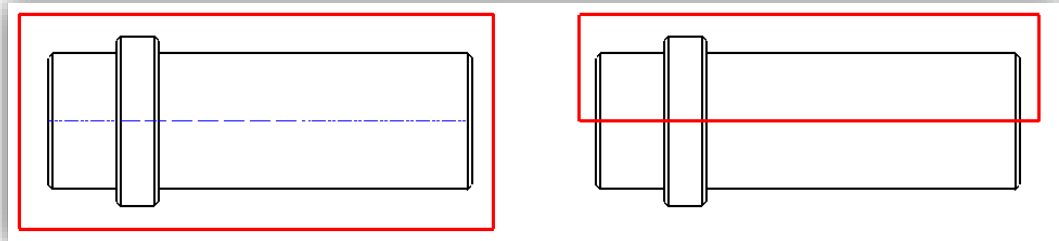

Use the "Broken-out section" feature to create a section view, with the depth linked to the part axis:

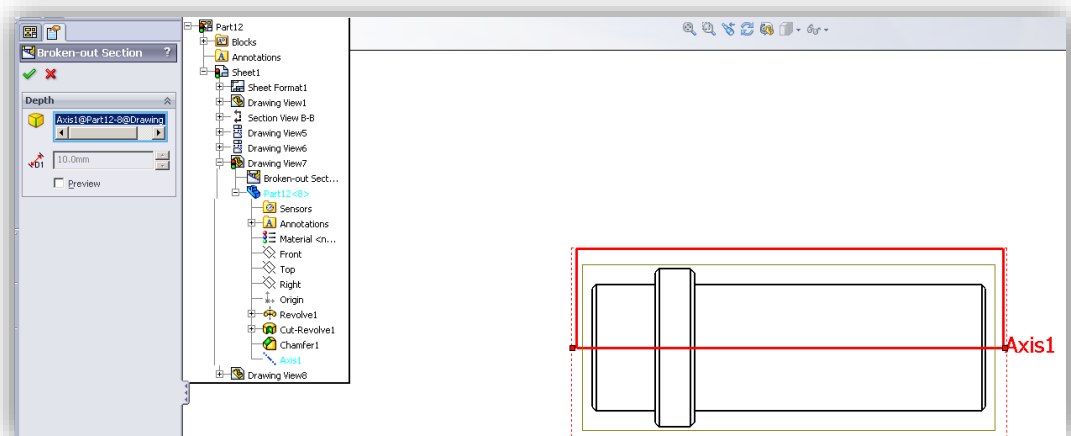

The following section view will be created:

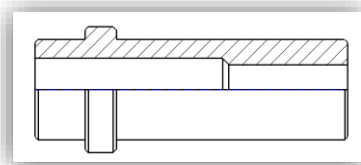

Important Notice!!!

Sometimes, after changing the location of a hole in the model file (see example 2), the section view does not update, that means that the section plane remains in the previous location. Far worse than that, there is no indication in the drawing that there was a change or an update which can lead to wrong dimensioning that will be followed by manufacturing errors.

It is a mandatory must to link the depth of the view to a coordinate system, a plane, etc. and to check each time that the section view is fully updated!
Because of the above issue, it is advisable not to use Broken-out section.

8. Auxiliary View And Detail View

8.1. In a part that has an inclined surface or any other feature that is not parallel to one of the main three planes, Auxiliary View can be used in order to show the part feature correctly. The Auxiliary view will be positioned aligned with the Auxiliary view indicating arrow.

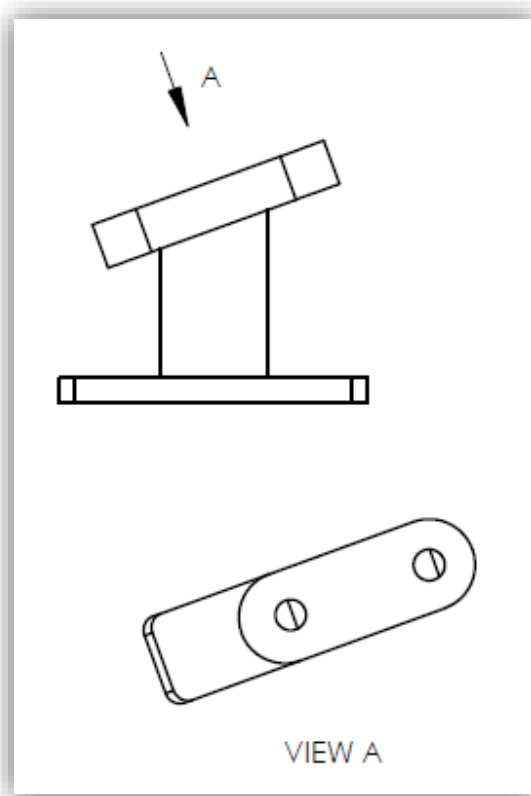

8.2. A Detail View is used to magnify part of a projected view or a section view in order to clearly see the relevant detail in the drawing. The Detail view is labeled as following:

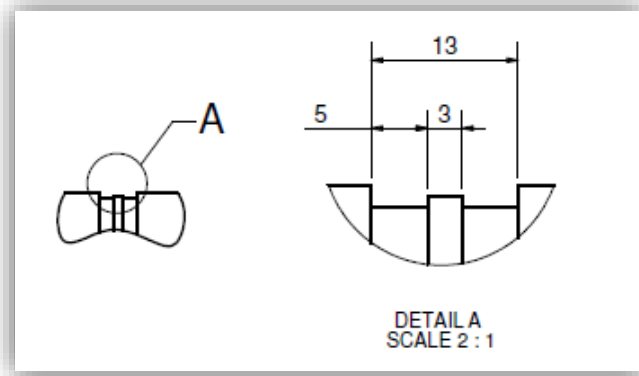

Notice: One should always remember that two options are available: Detail view or changing the drawing scale in order to see the required detail, and that the best out of the two should be selected.

8.3. The letters that label the view must not be crossed with body lines or given dimensions.

9. Thread Marking

Threads should be marked as in the following examples:

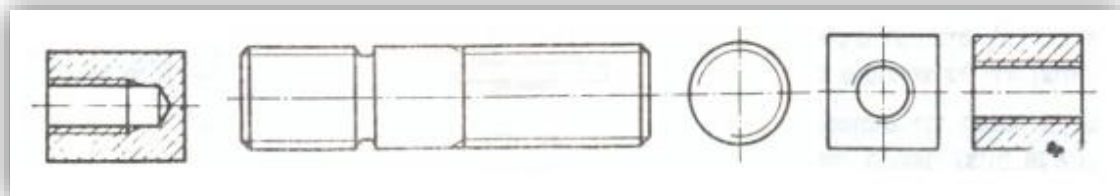

10. Dimensioning

10.1. General principles

- 10.1.1. Do not dimension hidden lines!
- 10.1.2. Do not dimension a feature twice in the same drawing! A dimension should appear only once, but if the dimension required for better understanding, the dimension will be marked with parenthesis (Reference).
- 10.1.3. A feature dimension will be given in the same view where the feature is most clearly visible.

10.1.4. If a dimension can be calculated (mathematically) from other, already given, dimension, the dimension will not be drawn unless it will appear inside parenthesis.

10.1.5. Dimensions Are Before Finish! (The designer must consider the finish thickness, usually only for high precision parts - microns tolerances). See Ziv-Av Engineering - Work procedure W004 - Dimensions Before and After Finish.

10.2. Dimensioning

10.2.1. Dimension positioning: the dimension will be drawn as close as possible to the middle of the dimension line, and above it. The dimension will be drawn parallel to the dimension line (horizontal or vertical) except for drill holes/threads dimensions, where the dimension will be always horizontal (see example below)

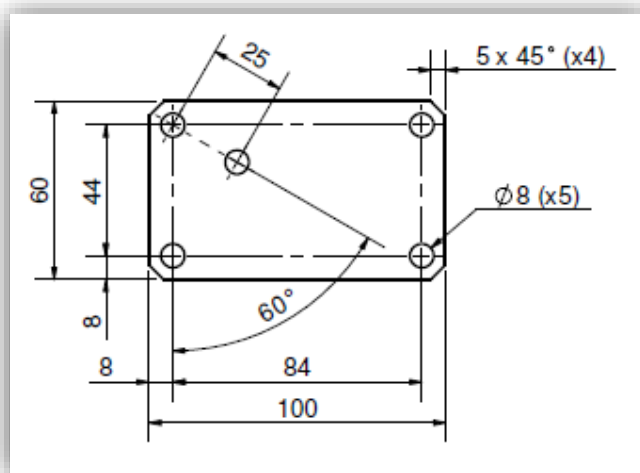

10.2.2. A vertical dimension will be positioned horizontally when dimension tolerances or geometric tolerances are added, in order to allow simple reading.

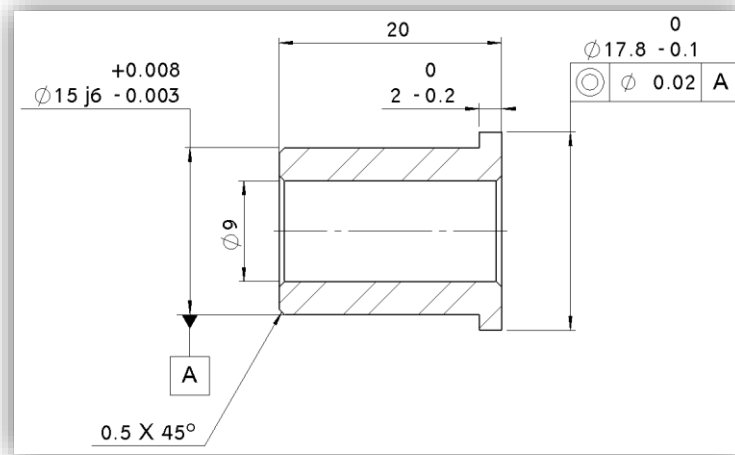

10.2.3. It is preferable that the dimension lines do not cross each other. In cases where there are a number of dimensions that need to be given on the same part side, the smallest dimension will be closest to the part body and the largest dimension will be far.

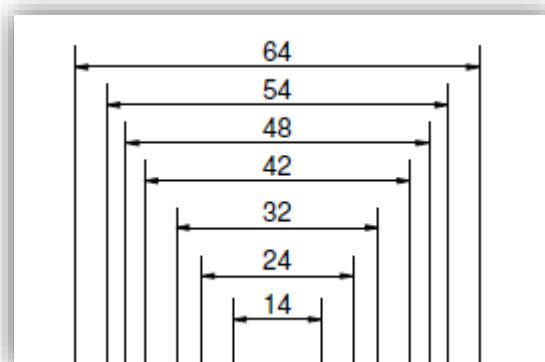

10.2.4. Where it is impractical to position the dimensions in the preferred way mentioned above, the dimensions can be positioned as shown below:

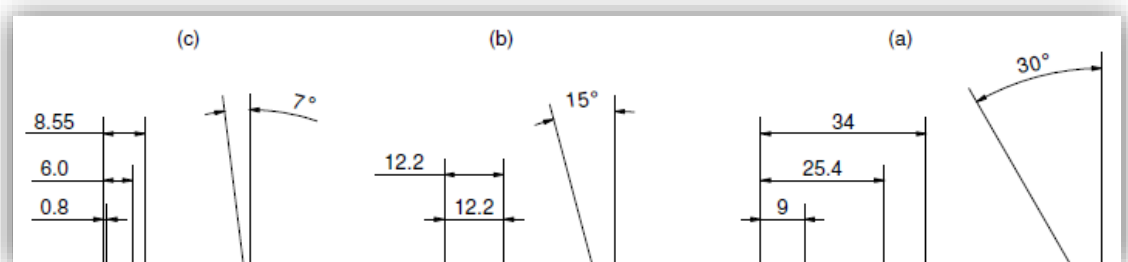

10.2.5. Grouping dimensions

Whenever possible, all dimensions should be aligned and grouped together on the same side of the part for unified appearance and to allow simple reading.

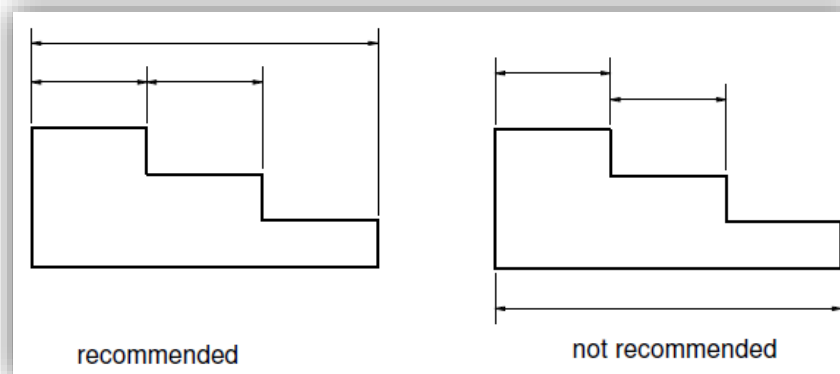

10.2.6. Dimensions should not be positioned inside the part body area but should be positioned outside of it, with the use of the dimension lines as shown below:

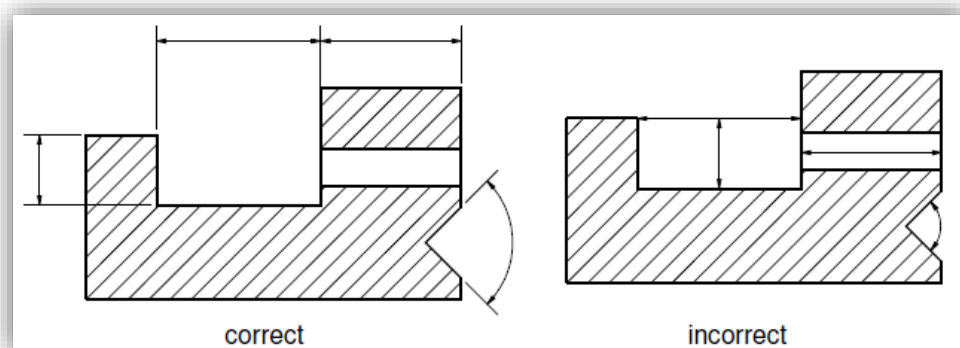

10.2.7. Dimensions to theoretical corners

Parts with filleted corners should be dimensioned using the part theoretical lines.

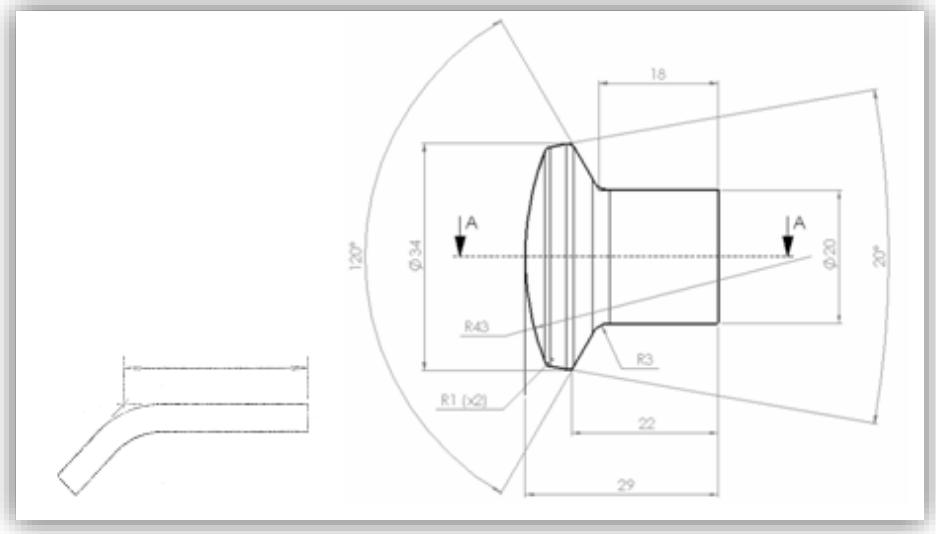

10.2.8. Leader

The leader should end with an arrow when touching part body lines or a point when pointing part body surface.

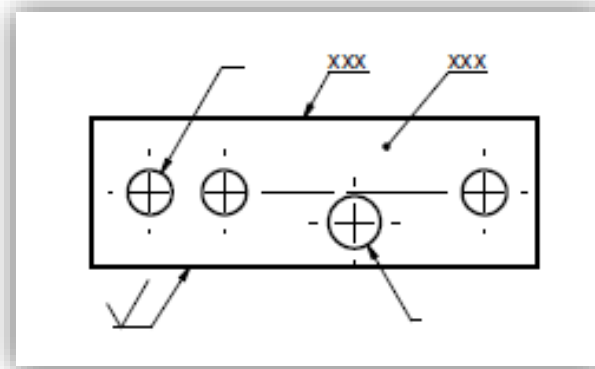

The leader should be used as follows:

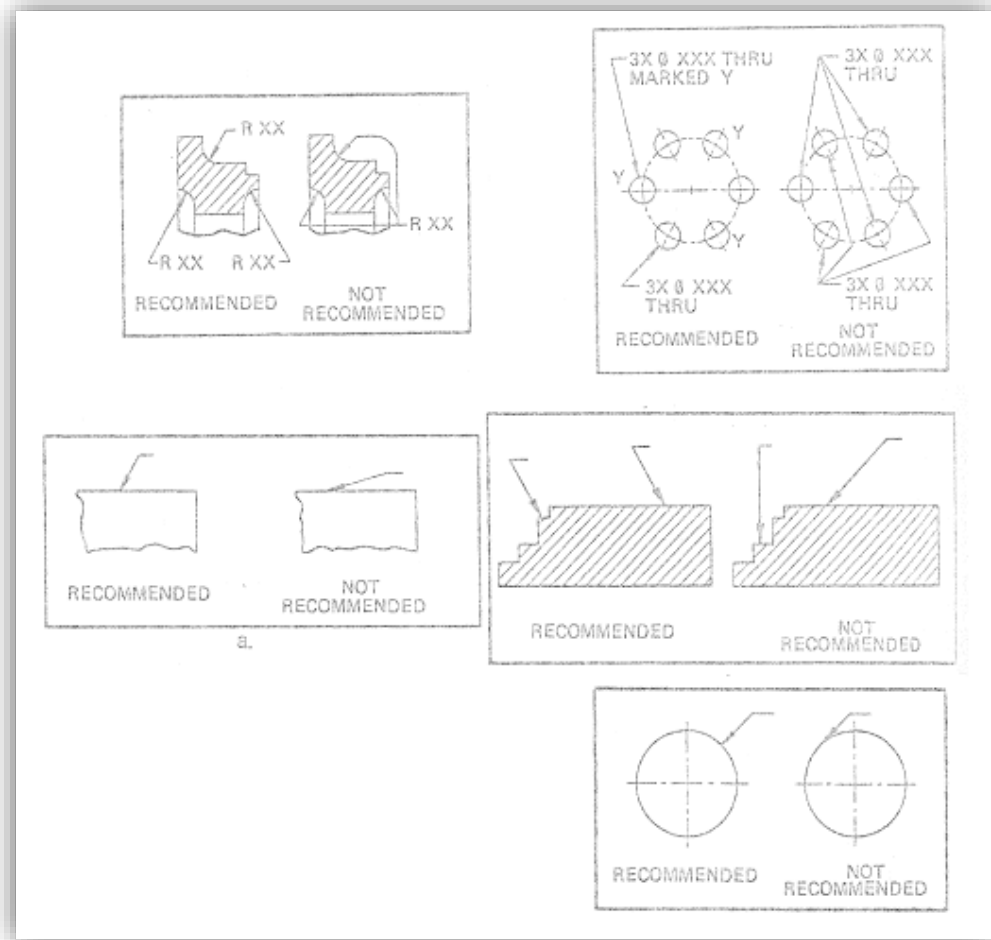

10.2.9. The side for positioning and grouping the dimensions will be selected according to the Cartesian system, unless there is a reason to put them in different position:

10.2.11. Chamfer dimensions

10.2.11.1. 45° angle chamfer only:

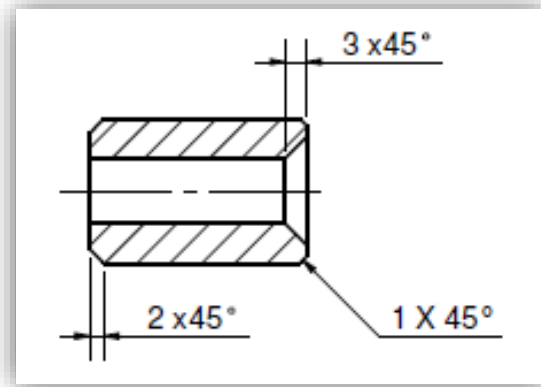

10.2.11.2. Any other chamfer:

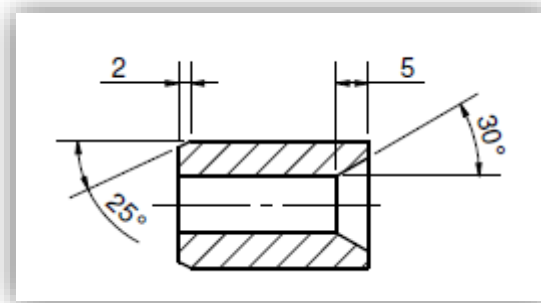

10.2.11.3. Chamfers for cutting surfaces in angle other than 90°:

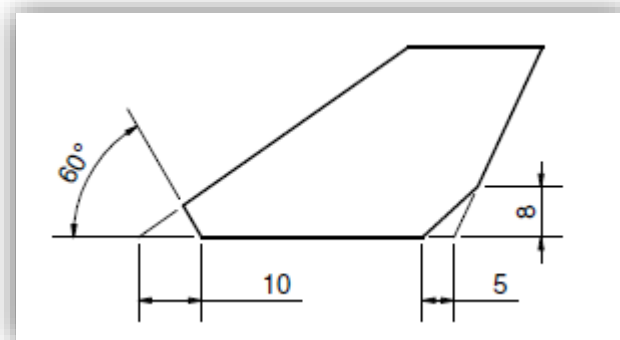

10.2.12. In relatively large parts that are drawn in small scale, one should check that the dimensions are from the external part lines and not from internal lines (like a chamfer or RHS profile end cup) that are positioned close to the external line.

One should zoom to check that the dimensions are drawn from the right part feature!

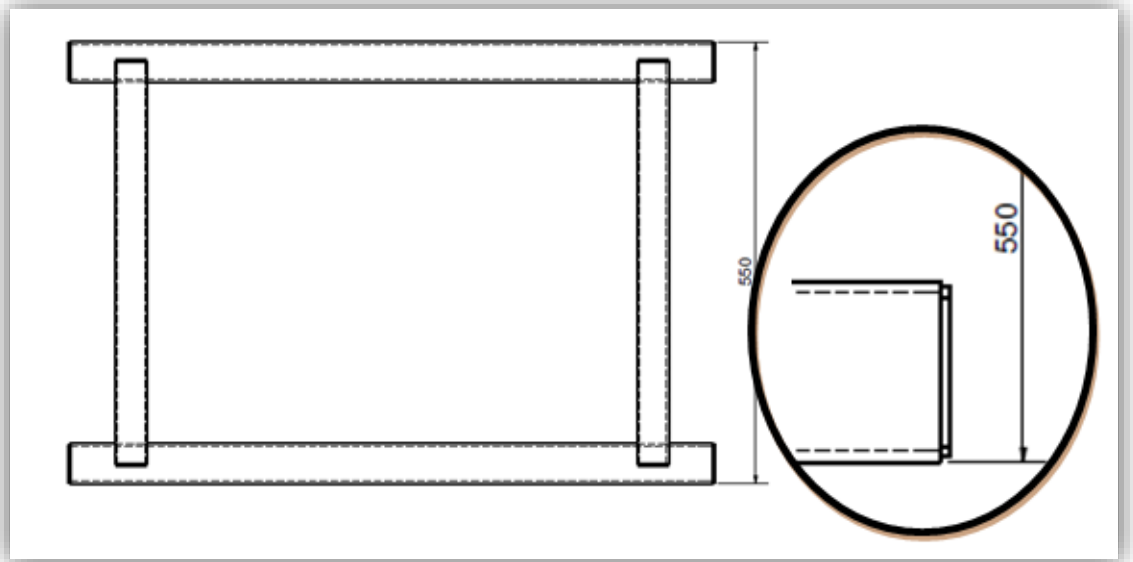

Notice: The magnified detail in the drawing above is shown for demonstration purpose only! One should not add the magnified detail on the drawing, unless a weld symbol for the RHS profile end cup should be added.

10.2.13. The use of a "square" symbol where horizontal dimension and vertical dimension of a feature are equal - is not allowed (see image below). The reason is that there might be a change in the model of either the vertical or the horizontal dimension, without it being reflected in the drawing, because there was no dimension drawing originally. Both dimensions are always to be drawn.

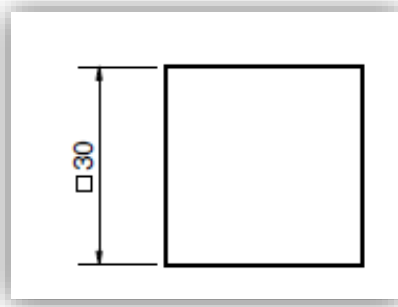

- 10.2.14. The use of STOCK dimensions (the original dimensions of the raw material that are not processed later on) will be drawn as shown below (one should not use the THK. Notation). The dimension should be rotated for ease of reading (example below).

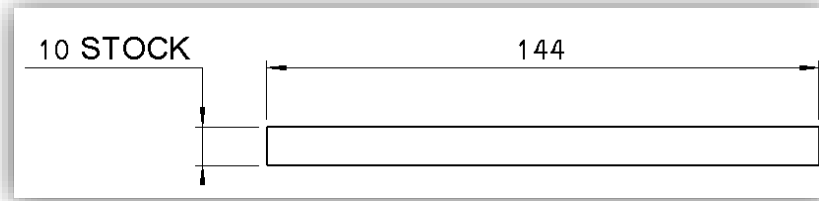

- 10.2.15. Dimensions for key hole will be drawn as follows:

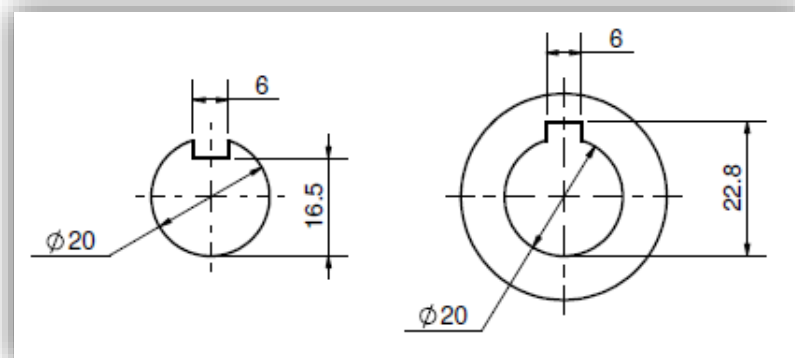

- 10.2.16. Dimensions for equal spaced features

One should use the method below to add dimensions for equally spaced features. If there is a chance of misunderstanding, one needs to indicate which one out of the two refers to the distance.

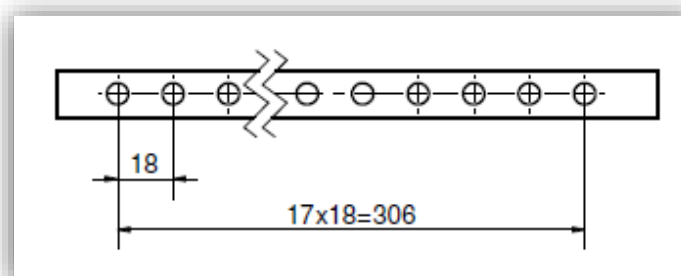

- 10.2.17. Dimensions for equal spaced circular features

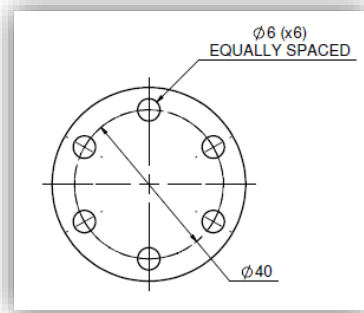

10.2.18. Slot dimensions

10.2.18.1. For machining manufacturing

The slot outer dimensions should be added (in order to allow the manufacture to machine with different radii tool if part functionality allows, and because the slot is usually machined in several go until reaching the desired radii).

"FULL R" indication is added only if it is important for the part functionality.

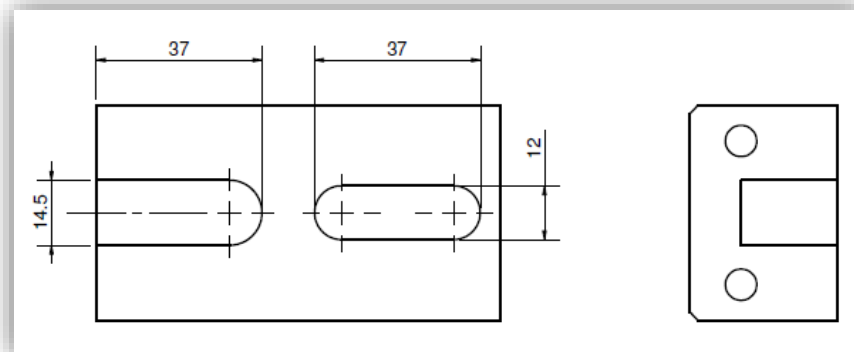

10.2.18.2. For CNC punch or laser cutting for sheetmetal parts:

It is acceptable to give outer dimensions or inside dimensions and radii.

10.2.19. Ordinate dimensions

- Highly detailed parts, where normal dimensioning will over crowd the drawing to a level of it being unreadable, it is customary to give Ordinate dimensions.
- The ordinate dimension zero point should be selected according to the significance of the main part feature. In the example below, the zero

point is in the center of the left lower drill hole (and not at the part edge).

- When there are many dimensions, the zero point can be given twice, from both sides of the part, and the dimensions will equally spread between them (left/right and up/down).

See example below.

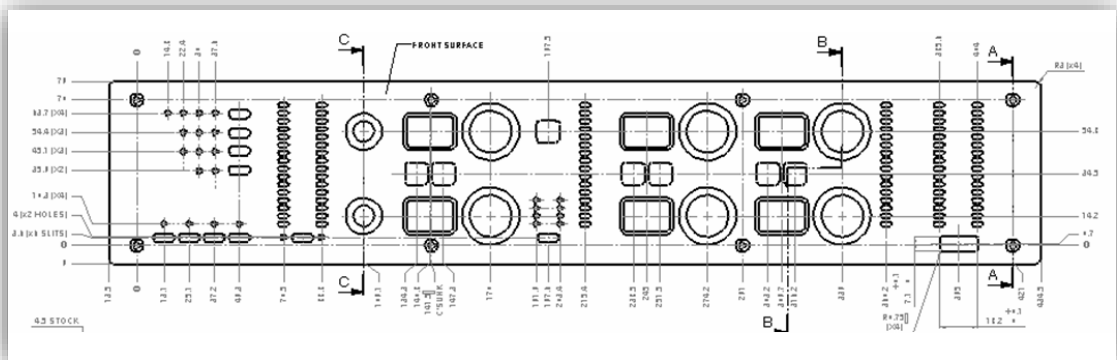

Notice: The zero point that was selected is the same in all the other views of the part in the drawing.

10.2.20. Slanted dimension

When a dimension is drawn from points on a surface, the dimension will be slanted. In the following example, the right drill hole is perpendicular to the bottom surface, but the left one has an angle to the bottom surface. Therefore the dimension between the drill holes centers is correct only for the bottom surface, so it will be drawn slanted.

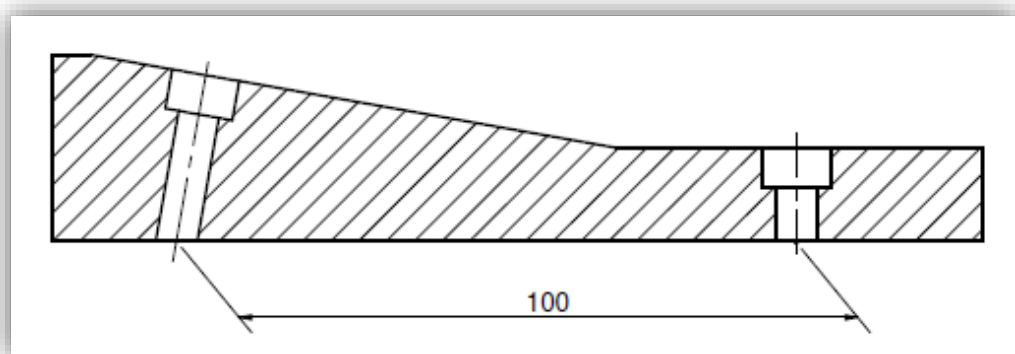

10.2.21. When a feature is repetitive in the same drawing view (like drill holes, or threads), the dimension will be given once with indication of the number of repeats in the same drawing view. The indication will be inside parenthesis with presiding "x" (lowercase) as shown below:

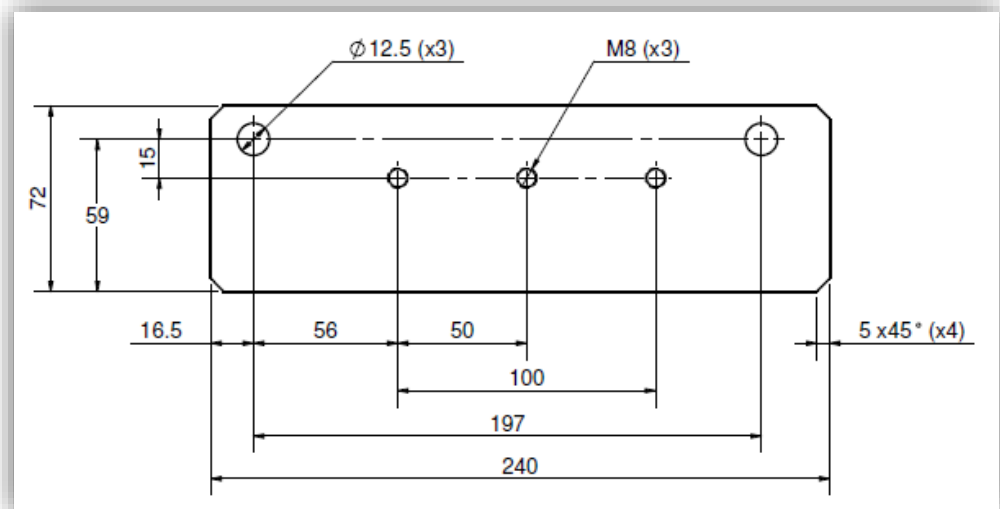

10.2.22. The use of "TYP." notation will be made only for repetitive fillet or chamfer (not applicable for drill holes). The notation will be made in capital letters and underneath the dimension. Alternately, the number of fillets or chamfers can be counted and notate accordingly.

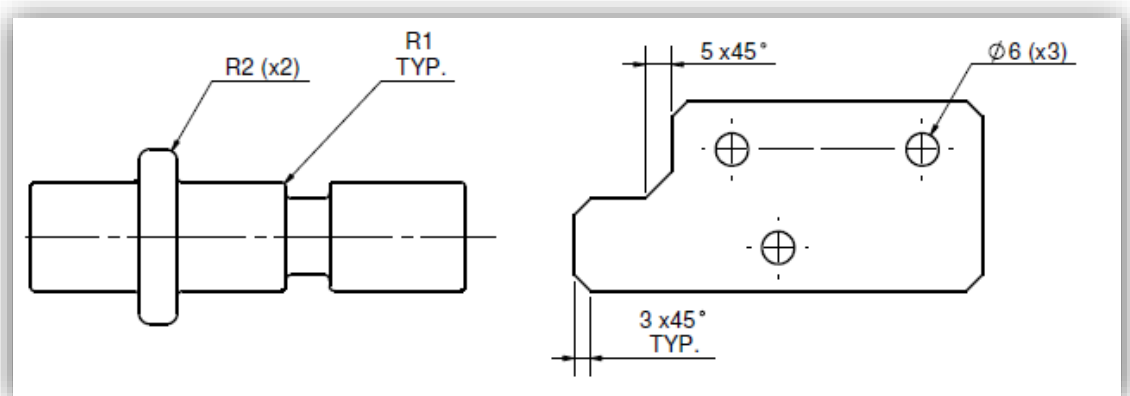

10.2.23. For identical features that appear in different views on the drawing, the count of repetition will be for each view separately. This rule applies

also to section views (a count for a feature that is shown only in the section view). See examples below:

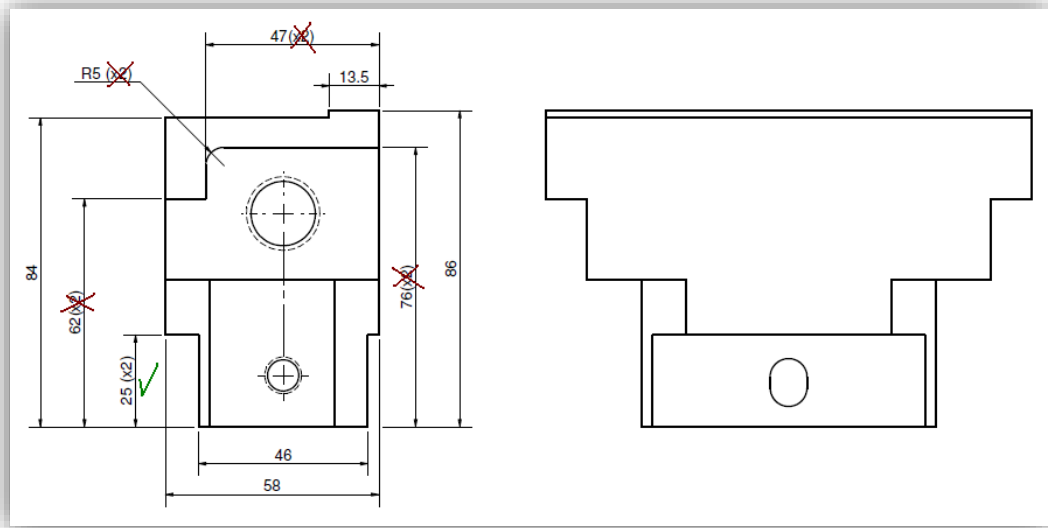

Wrong

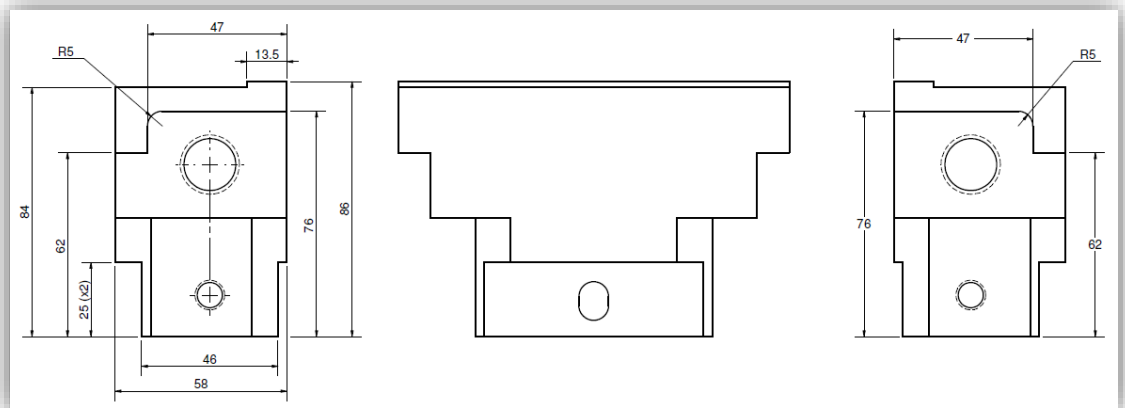

Right

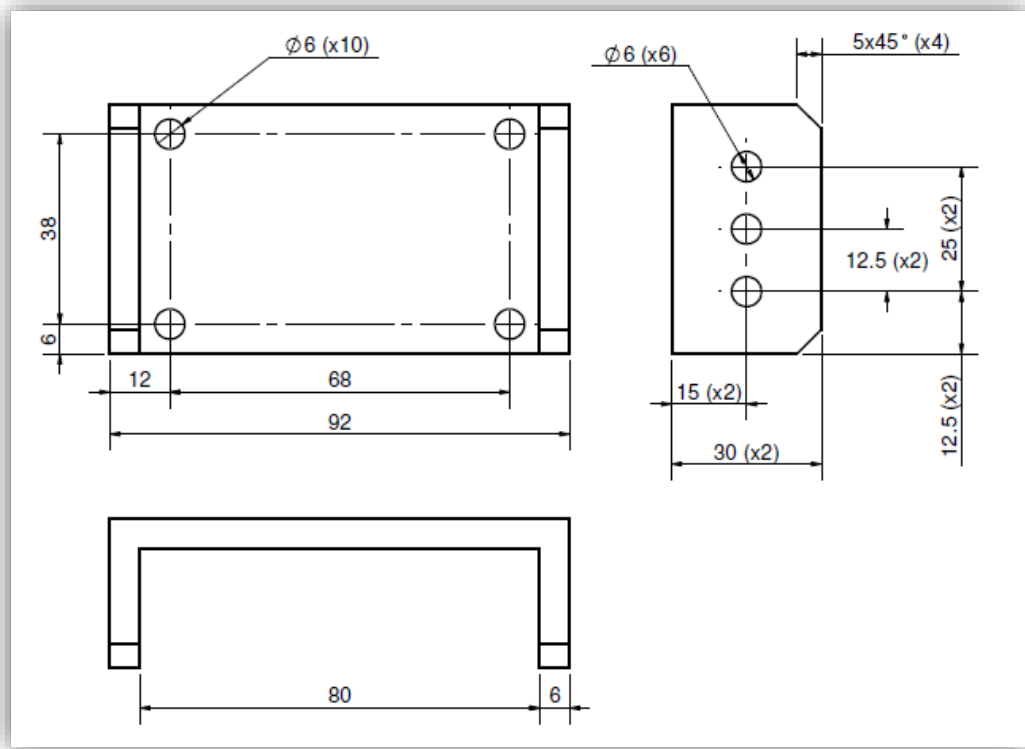

Wrong

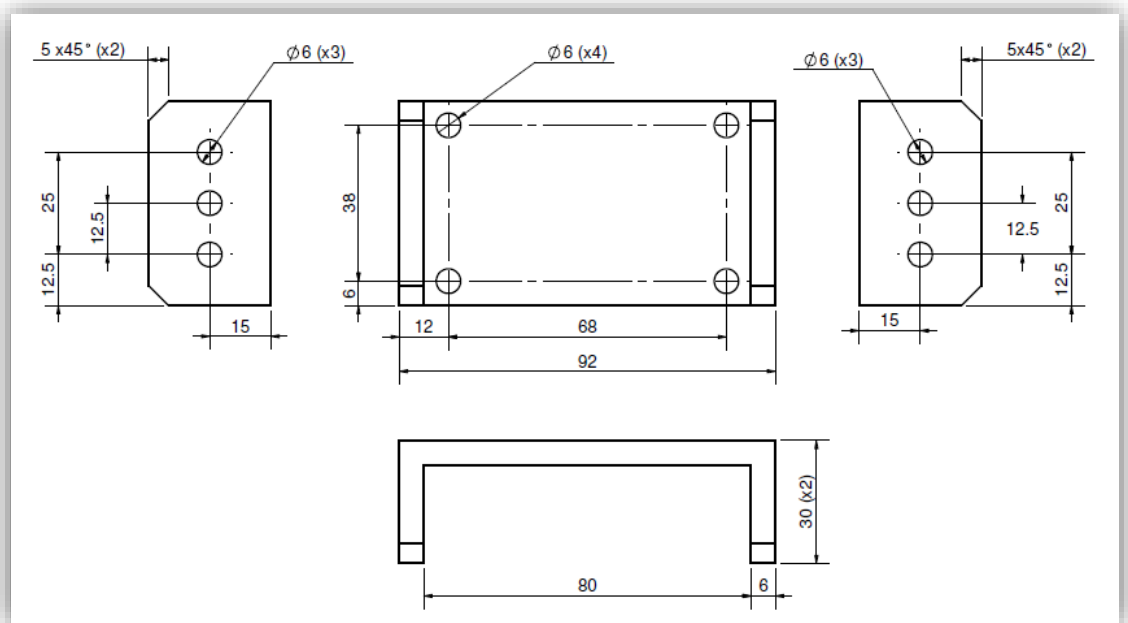

Right

If all the features in two separate views are identical, the following applies:

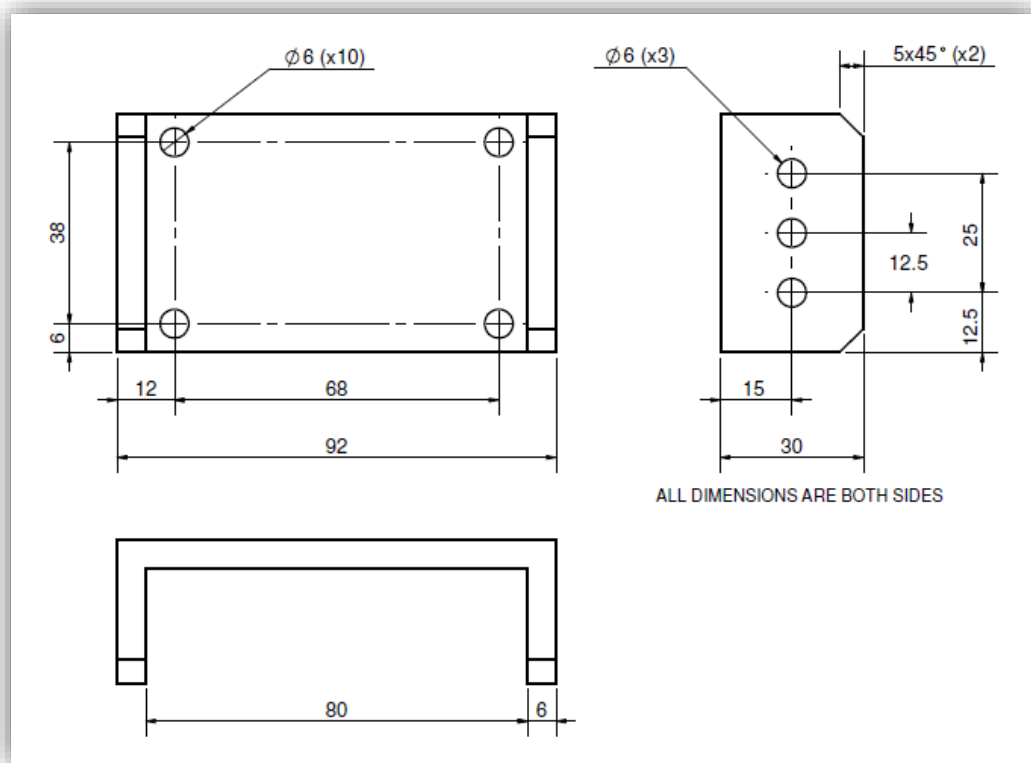

10.2.24. If a view or a section view is noted as typical (under the shown view will be added the number of repetitions as "TYP. 2 PLACES"), one should check that all the features that are shown in that view are indeed identical to all the features in the other places (If not, the view will show only the identical features). See example below:

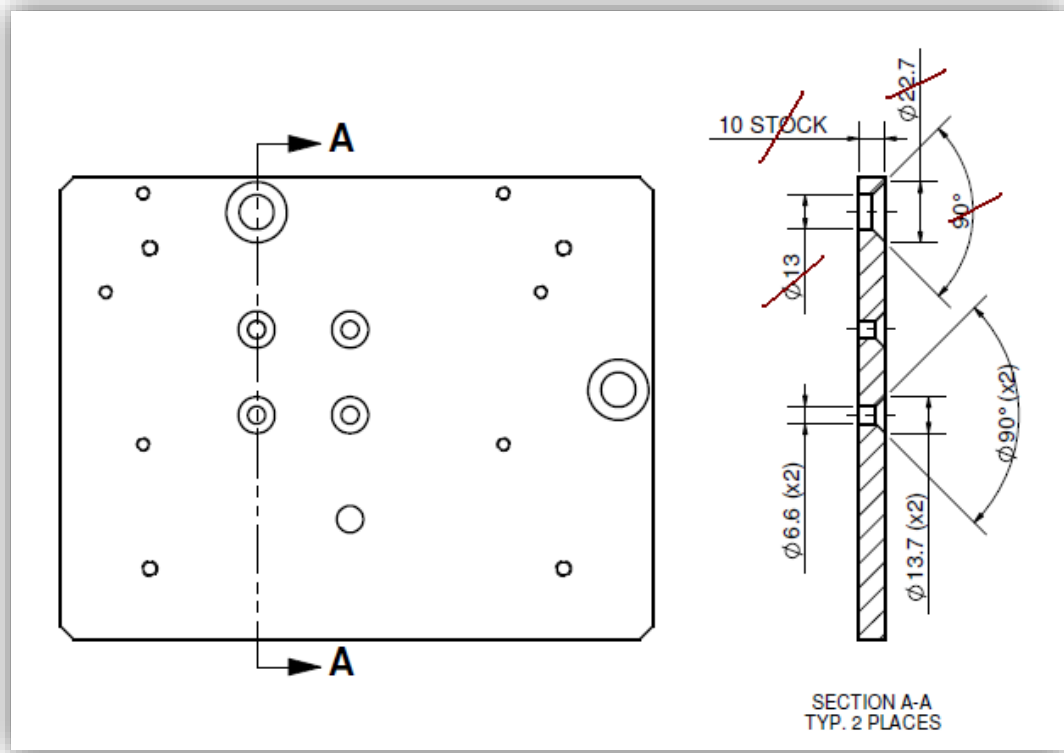

Wrong

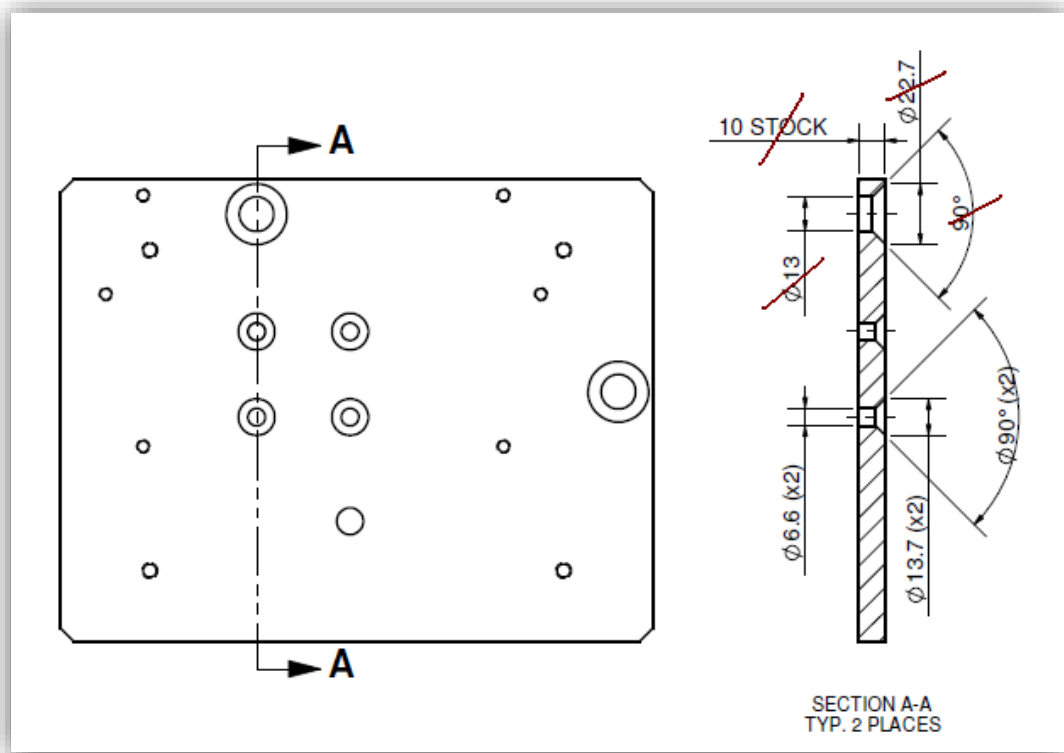

Right

10.2.25. Threads depth

In machined parts, where there is no indication for the depth of the drilled hole or the thread, it means the hole/thread passes through the whole part; otherwise the depth must be given.

10.2.25.1. For profiles

If the drilled hole or thread is only through one side of the profile, the "THIS SIDE ONLY" notation should be added under the dimension.

If the drilled hole or thread is through both sides of the profile, the "BOTH SIDERS" notation should be added under the dimension and another projected view for the location on the other side should be added with dimensions in parenthesis (reference) for the drilled hole / thread.

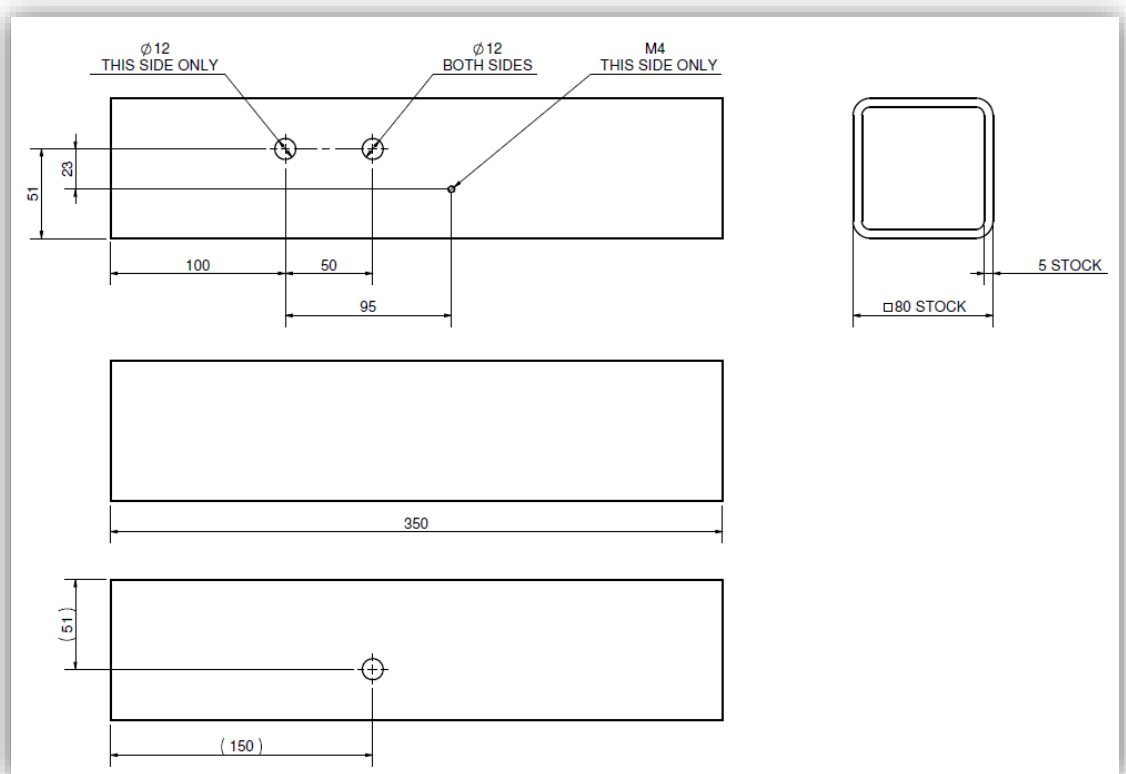

10.2.26. Threads

10.2.26.1. Threads dimensions will be given in one out of two ways:
 Using section view with dimensions or using the "Hole Callout" Solidworks function, after deleting the drilled hole and tolerance data as shown below:

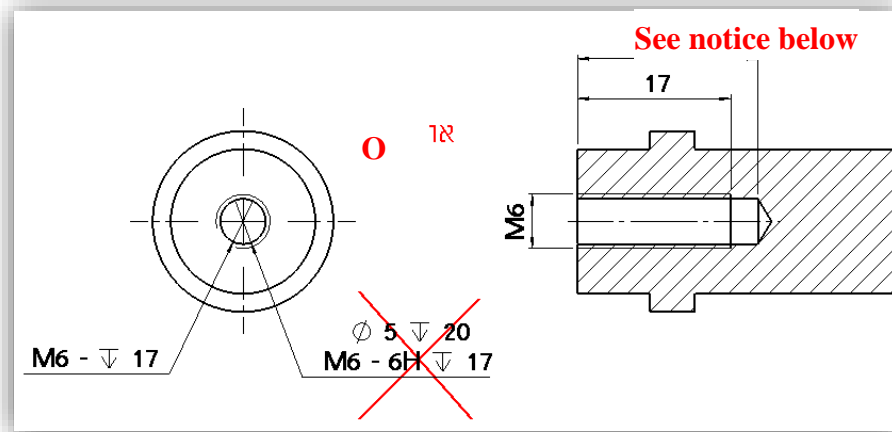

Notice: Drilled hole's depth is only dimensioned if it is important for the part functionality.

10.2.26.2. When using coarse threads, there is no thread pitch indication.

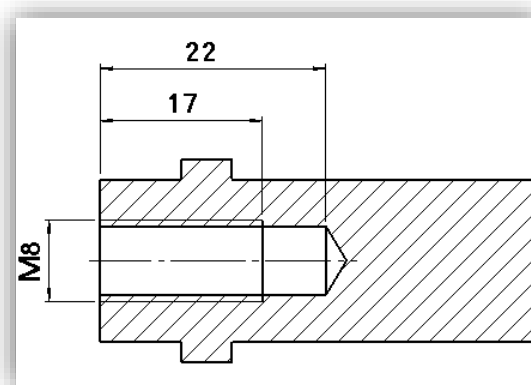

10.2.26.3. When using fine threads, there is thread pitch indication.

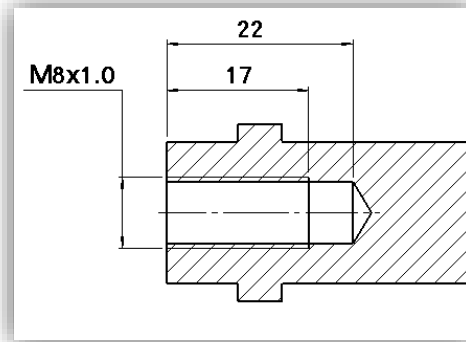

10.2.26.4. Unless otherwise indicated, the thread tolerance is standard (tolerance of: 5H-6H) and there is no need to indicate that.

10.2.27. Head clearance drilling for Socket head or Countersunk head screws
 It is possible to use section view with dimensions or the "Hole Callout" Solidworks function.

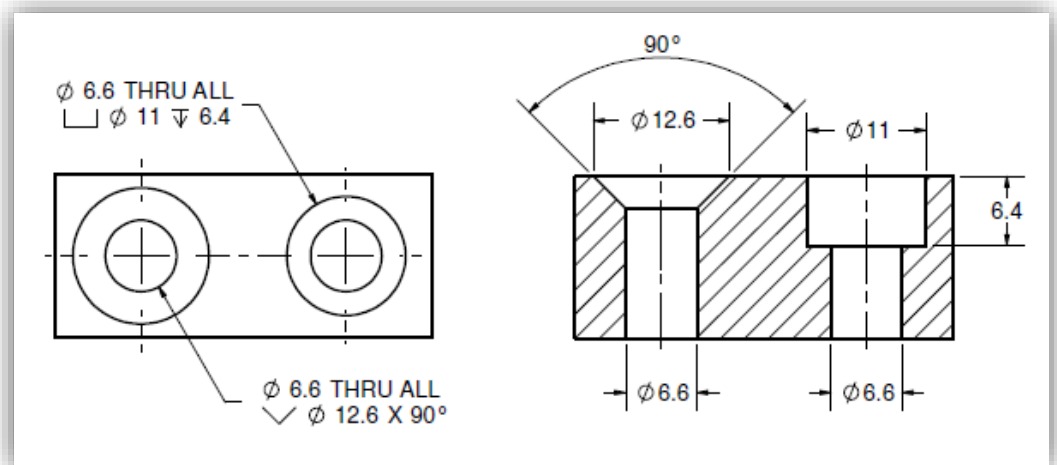

10.2.28. Dimensions for retaining rings for shaft/bores
 One should give the required tolerance for bore or shaft according to DIN 471/472.

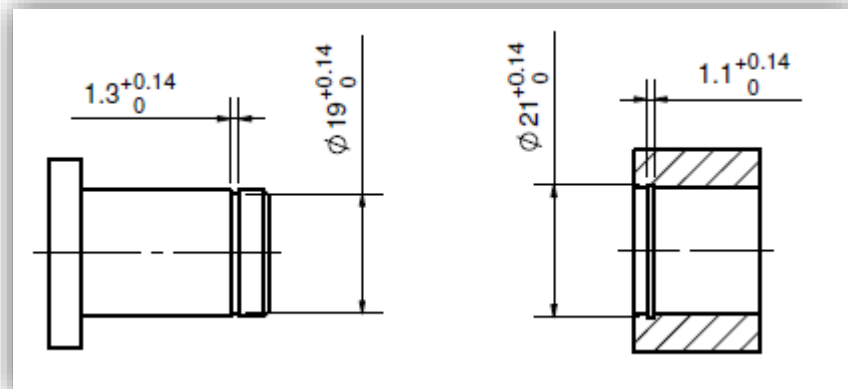

10.2.29. Labeling holes

Where a part has different types of drilled holes, which are packed together closely, in order to prevent confusion, one should label the holes (with capital letters) and also add the hole's label to the hole dimension (See example below).

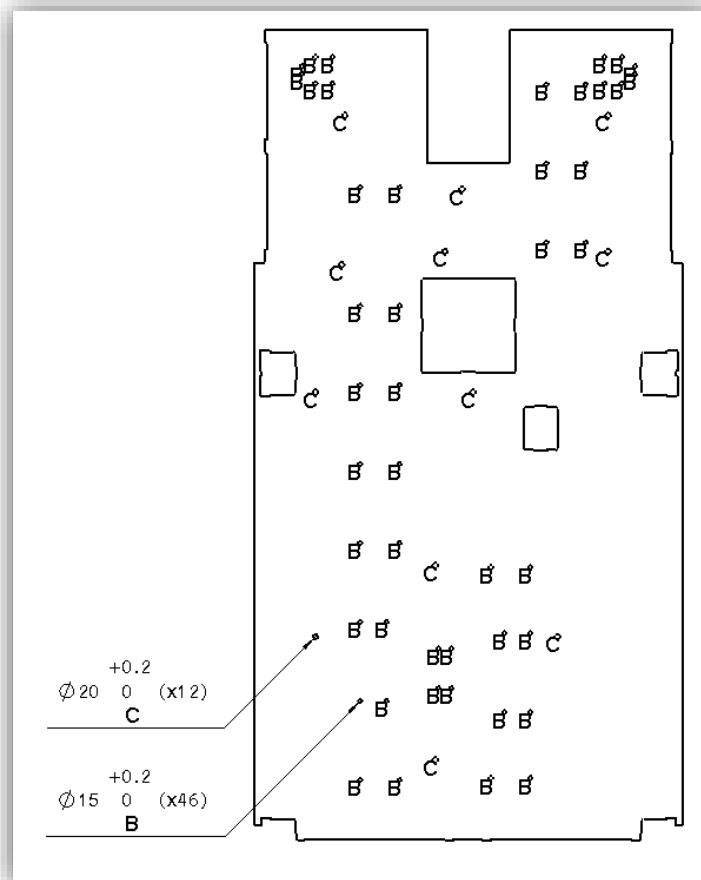

10.2.30. Tabular dimensions

When there are many drilled holes in the part, and it is impractical to draw all the dimensions, the following method is acceptable. A coordinate system is formed for drilled holes locations, each one of them is noted with a letter and a number (each group of same type of holes get the same letter). A table should be added to indicate the drilled hole's size, number of drilled holes, hole's location coordinates of X-Y and the required tolerance (see example below).

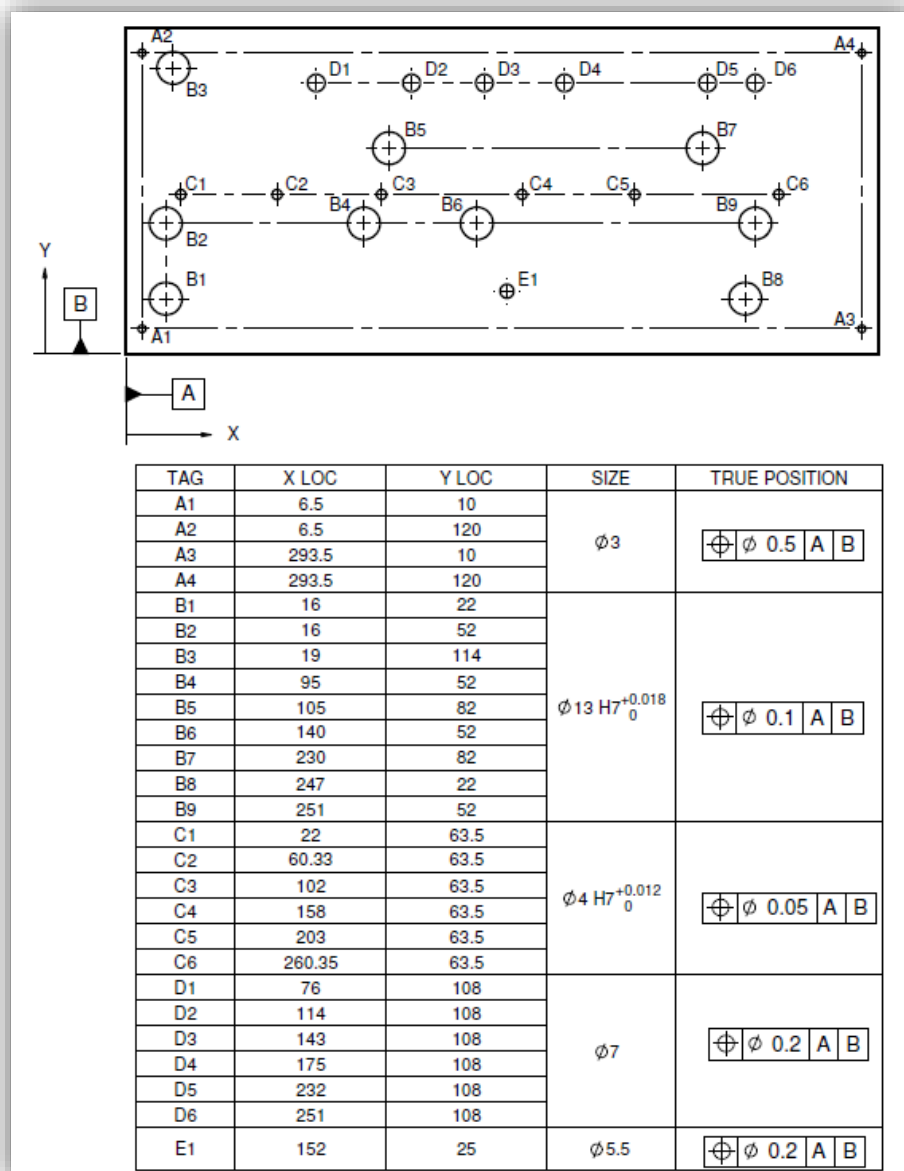

10.2.31. Sheet metal parts

- 10.2.31.1. To the sheet metal thickness dimension the word "STOCK" should be added.
- 10.2.31.2. All the dimensions should be given to external bends (unless the internal dimension is important) in a view that clearly shows the dimensioned bend.
- 10.2.31.3. Holes dimensions will be given from bend lines.
- 10.2.31.4. "MIN RELIEF" (with leader) should be noted between two close bends.

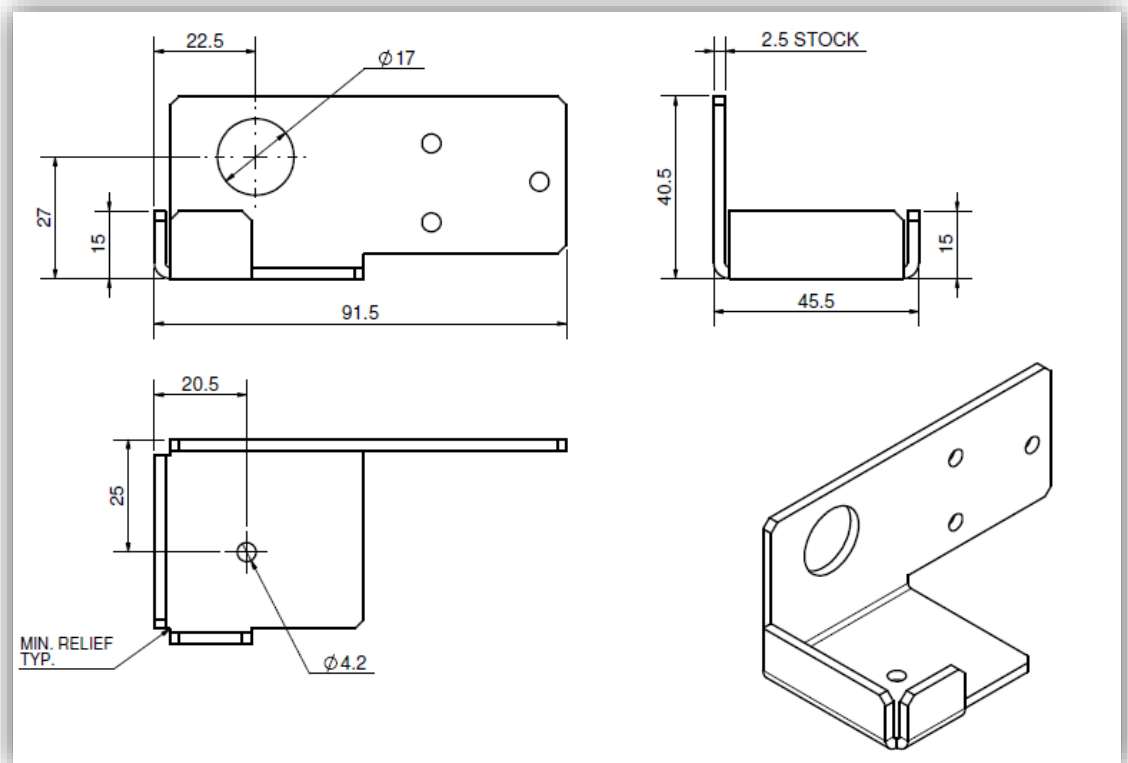

Sheet metal parts frequently have a lot of closely packed holes, which make dimensioning, especially with tolerances, difficult. In these cases ordinate dimensioning without tolerance indication is acceptable, as shown below, while adding a note as shown below:

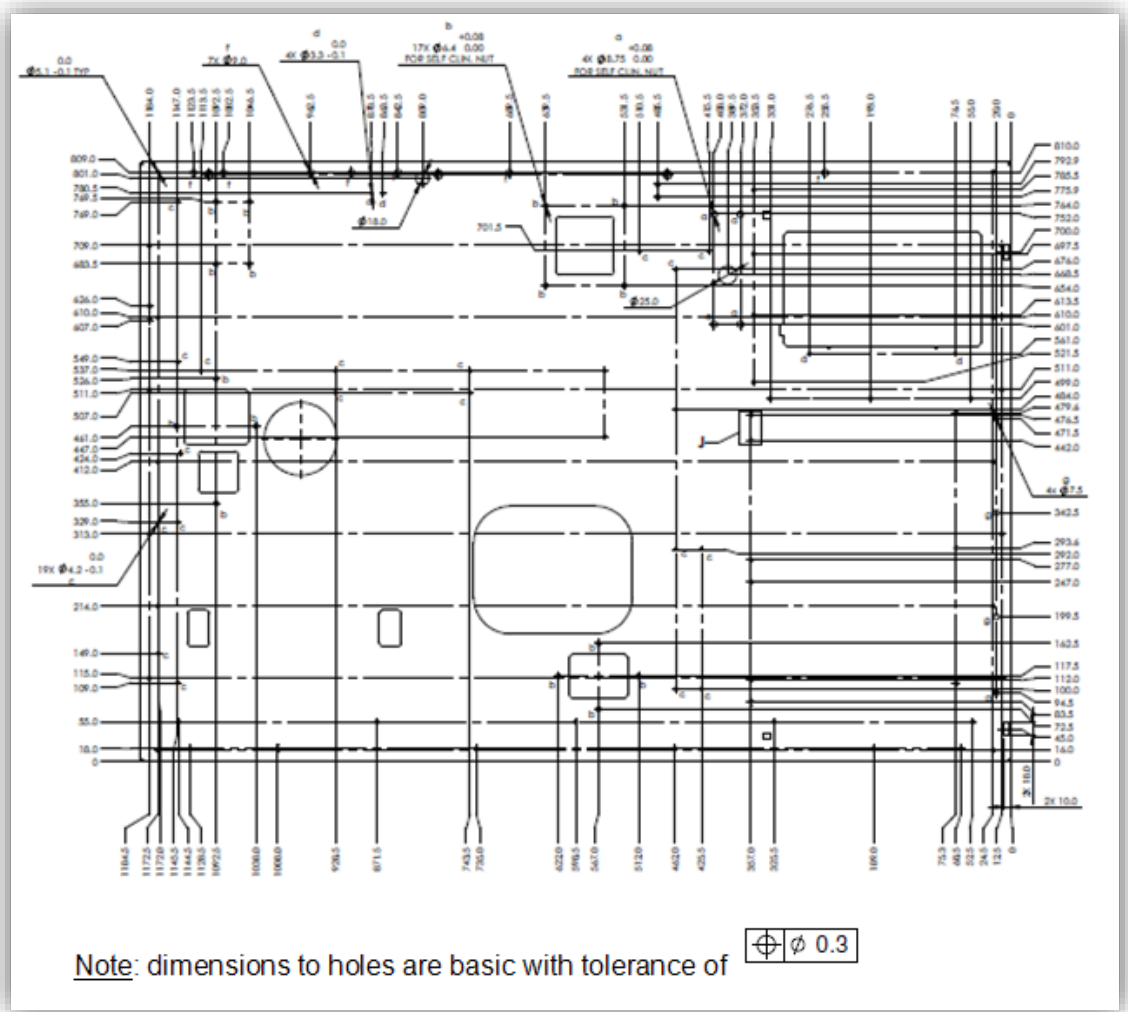

11. Drawings of parts with fasteners

11.1. Drawing Parts That Have Self Clinching Fasteners (PEM)

The part model is a sub-assembly of the sheet metal part + fasteners. The drawing will be composed of isometric view of the sub-assembly and projection view of the sheet metal part without the fasteners. One should be aware that the drawing title block custom properties are drawn from the first view inserted to the drawing sheet, so check carefully for details. The most important custom property is the "Revision" and one should check for the correlation between the model\assembly file data, the title block and the revision table.

Drawing procedure:

- Select the isometric view and insert a BOM table positioning it above the title block.
- Balloons will be added to the isometric view for the fasteners and the sheet metal part, which will always be marked as "1" while the fasteners are numbered sequentially.

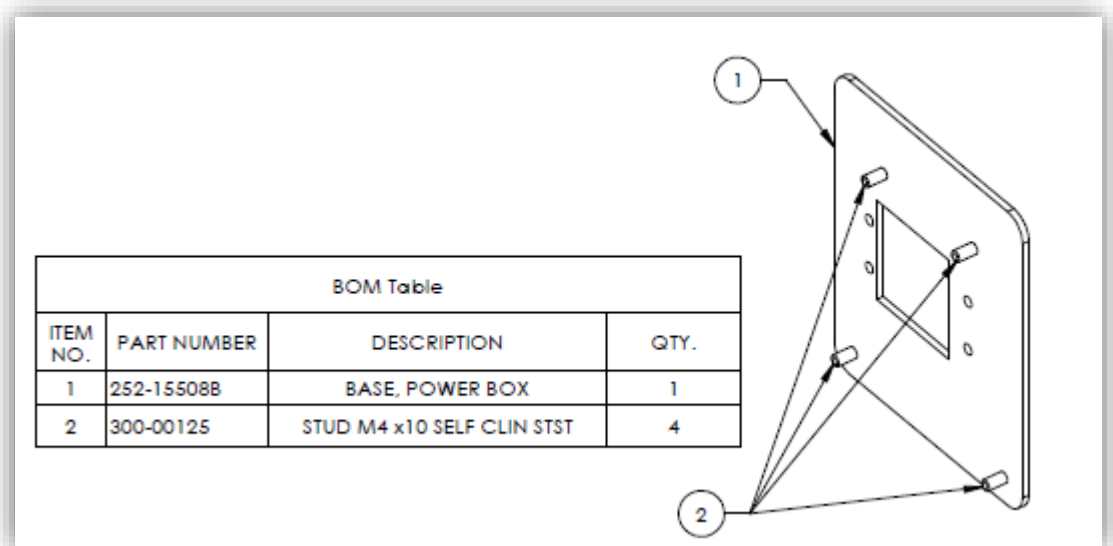

There is no need to hide the sheet metal part in the BOM table.

- Drilled hole for self clinching fastener (like PEM) has $x.xx^{+0.08}$ tolerance. The drilled hole size should be dimensioned with 2 digits precision with additional

note underneath the dimension (the note is added to the dimension function and not as a separated annotation):

"FOR SELF CLIN. STUD" or "FOE SELF CLIN. NUT"

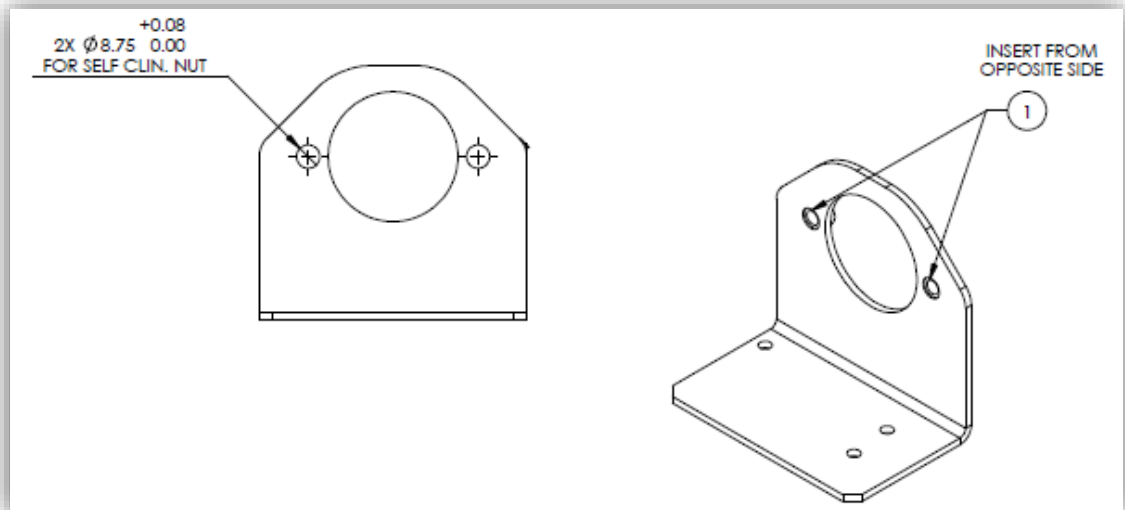

- Please noticed that occasionally, because of the large sheet metals part reduced scale; it is not obvious from which side the fastener is inserted. One should indicate the correct side of the insertion with the following notations, positioned next to the balloon (see example below and above):

"INSERT FROM THIS SIDE"

"INSERT FROM OPPOSITE SIDE"

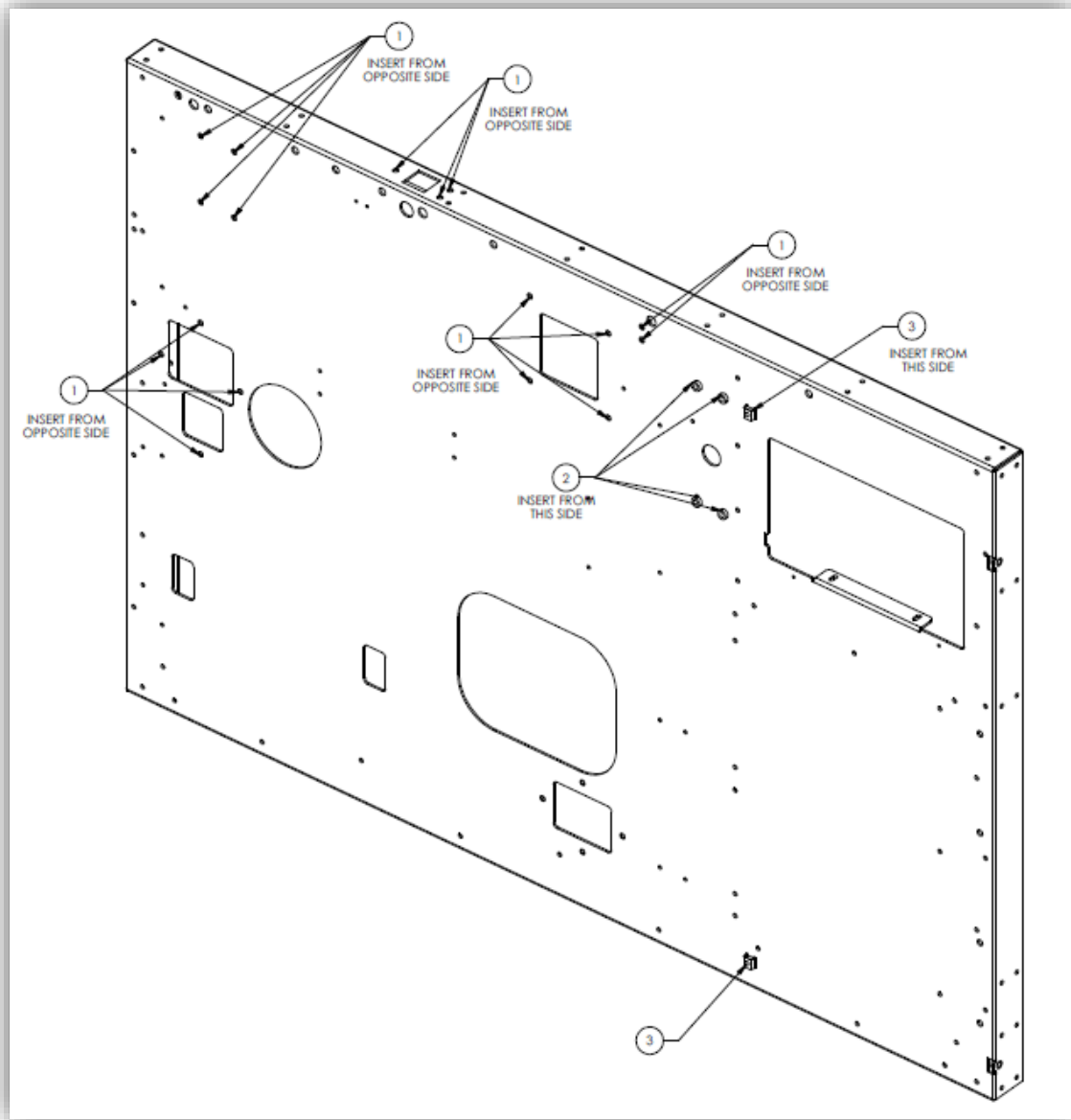

Furthermore, if possible, one should show the fastener magnified in a "Detail View" in order to clearly show the fastener insertion side.

11.2. Drawing of part with fasteners such as Helicoil or Keensert

In parts where fasteners such as Helicoil or Keensert are assembled, the model is a part only with a preliminary thread. In the drawing, the fastener will be presented in the following way:

- The preliminary thread will not be presented by a dimension, but by a note that will refer to the fastener itself and not to the thread size.

- A note will be added to the list of note (after coating), that will direct the manufacturer to add the fasteners as part of the manufacturing process.

See image below.

NOTES:

1. Unless otherwise specified, for part dimensions see model file. General tolerances apply.
2. Material: AA 6061-T6 Sheet/Plate Per ASTM B209
3. Dimensions are BEFORE COATING.
4. Mask threads up to M6 OR 1/4" before coating.
5. Finish: Black Sulfuric Anodize per: Mil-A-8625 Type II, Class 2, $15 \pm 5 \mu$; (RoHS Compliant)
6. Insert fasteners (HeliCoil) after coating acc. to drawing instructions.

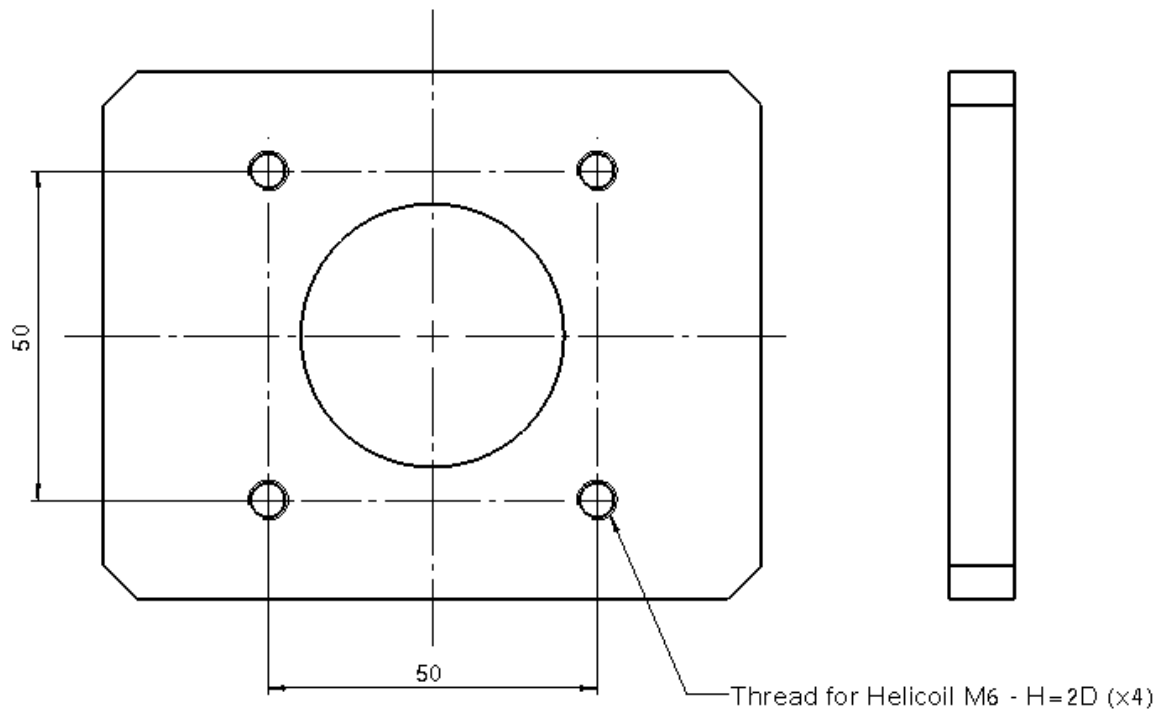

12. Welds drawings

12.1. For weld assembly drawing, general assembly dimensions (after welding) should be given and additional important dimensions.

In the next example, two sheet metal parts with $\Phi 24$ mm hole for pipe are welded. The drilled holes in these two parts are required to be concentric. One should add the right geometric tolerances and add a note that a tool for alignment should be used during the weld process to acquire the required concentric alignment.

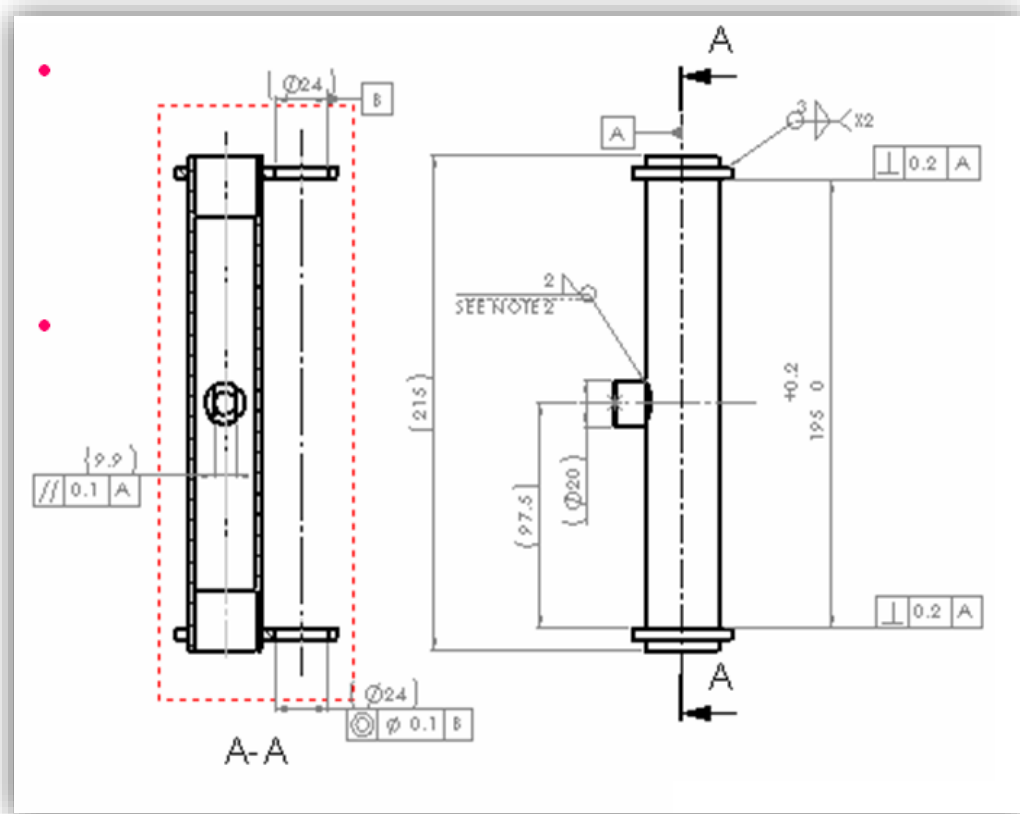

In the Notes list the following note will be added:

"Before welding, insert a rod $\Phi 24$ mm between plates no. XX."

In some cases, it is possible to use the assembly welded part as the tool for alignment. In these cases the notes will refer to the part number as the alignment tool.

12.2. For complex weld assemblies where the welding order is important, the drawing should be built using "STEPS" that will clearly define which welds are made in each of the steps:

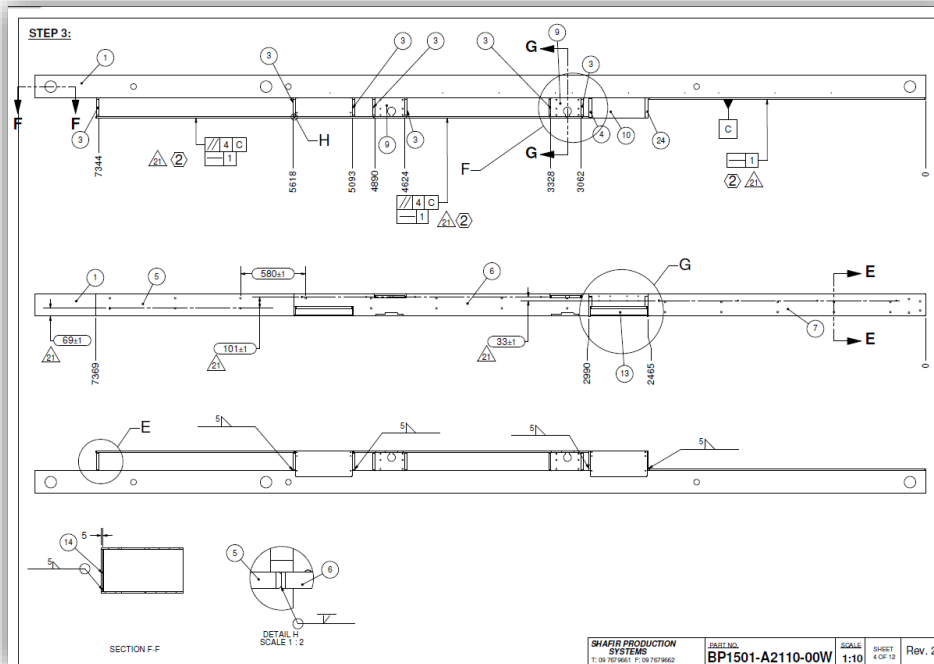
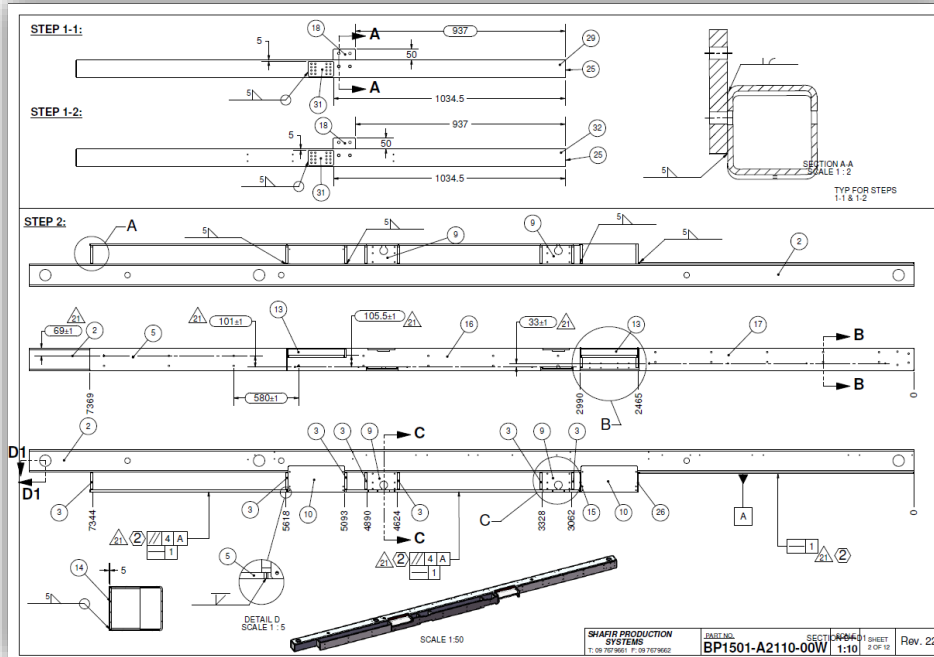

13. Assembly drawing

Assembly drawing shall include the following:

- 13.1. Views of the assembled assembly with the external width, length and height dimensions in parenthesis (for assembly size information) and an isometric view of the assembly.
- 13.2. Ballooned exploded view (if required). It is allowed to add several views to show the assembly from different angles.
- 13.3. All the balloons will be aligned on the same imaginary line (horizontal or vertical), and it is acceptable to create several groups of balloons on the same alignments line.
- 13.4. BOM table should be positioned above the drawing title block. The BOM table titles should be on the table bottom side.
- 13.5. The assembly approximate weight should be added to the drawing notes.

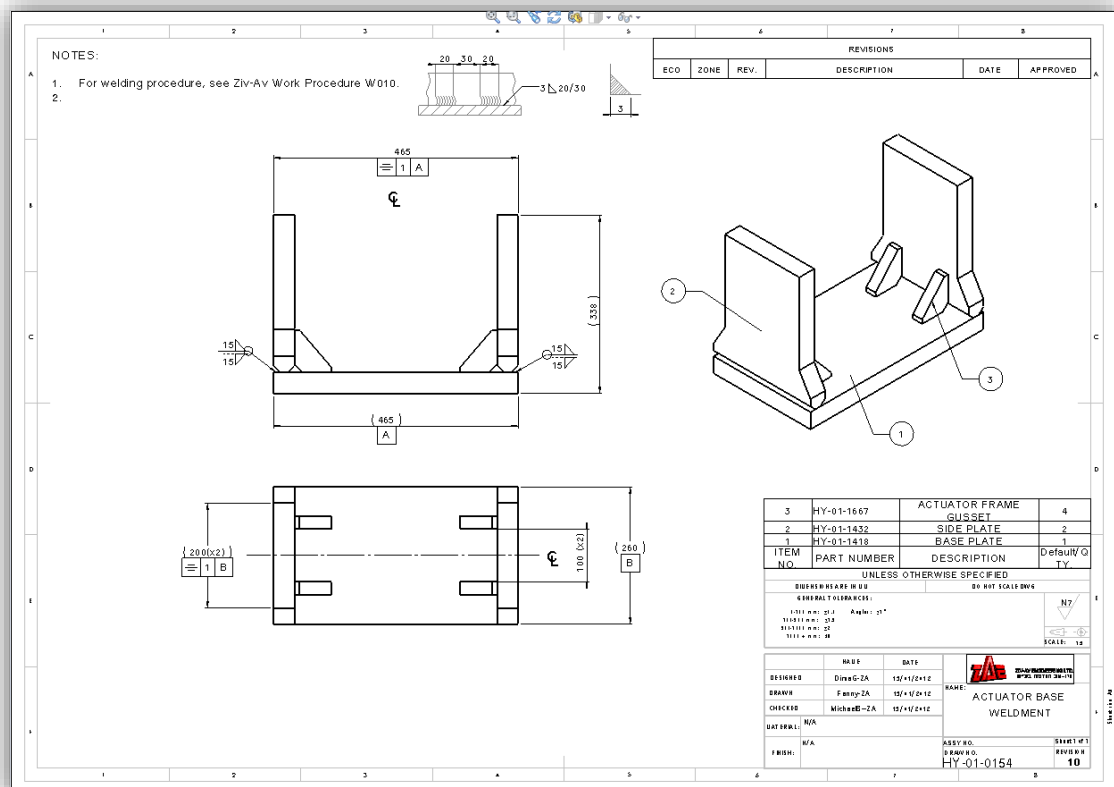

- 13.6. In case the BOM table is too long, it should be positioned on the left side of the drawing sheet, and the sheet notes should be positioned above the sheet

title block. If the BOM table is too long for the drawing sheet height, it should be split (see example below).

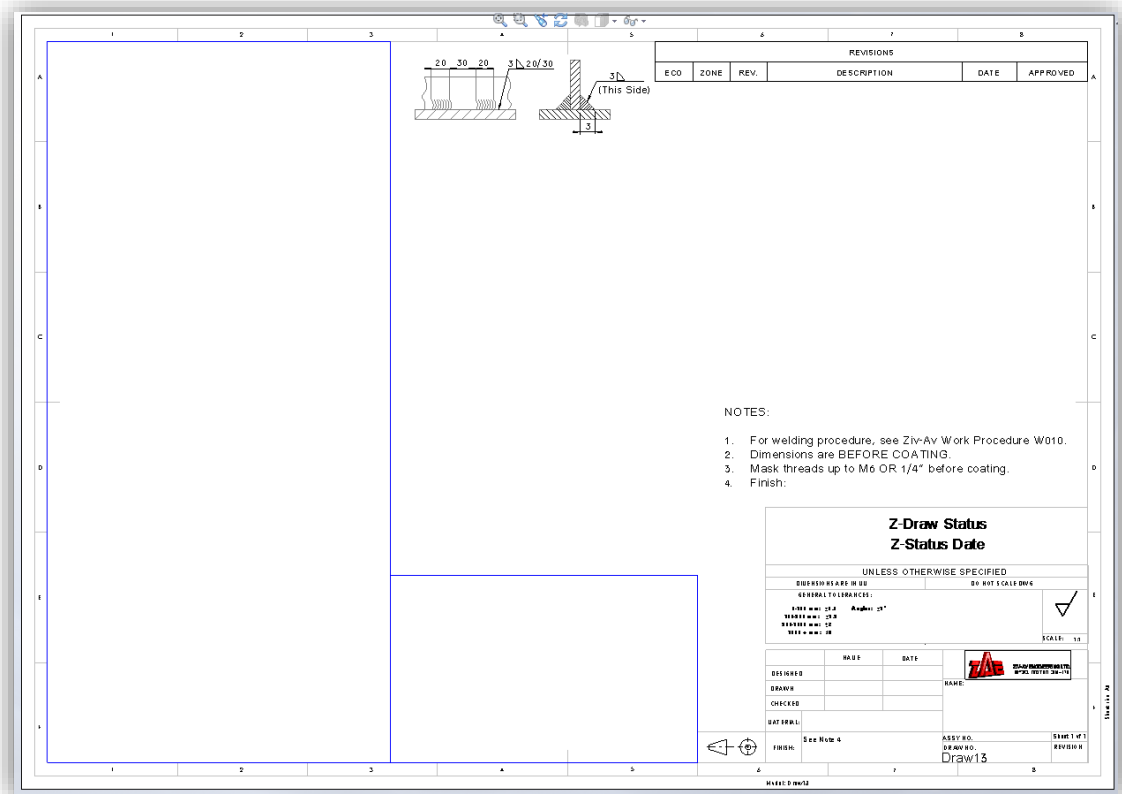

14. Revision table (ECO)

- 14.1. A numbered triangle should be positioned near the changed dimension with the relevant revision number. If the Revision table has a "ZONE" field, the triangle position area should be noted.
- 14.2. In the revision description field, one should describe the dimension size before the change, for example:
"Dimension 50 was changed to 52"
- 14.3. If the part had many changes, or major ones (and there is no room to describe them all), the description shall be: **"Part redesigned"** without using triangles in the drawing sheet.

14.4. The Revision table ECO field should be filled with the relevant ECO (Engineering Change Order) number, as every change is accompanied with an ECO.

14.5. One should use the past tense for the change description. For example:

- Holes dia. 6 were added
- Fillet/chamfer was added
- Hole was deleted
- Dimension 50 was changed to 52

REVISIONS					
ECO	ZONE	REV.	DESCRIPTION	DATE	APPROVED
#20	D2	11	CHANGE SLOTS TO HOLES	24.04.12	Tal G.

15. Dimensioning methods

Unless it is otherwise decided at the beginning of the project, drawings will be made in the following way:

Type of Drawing	Dimensioning method
Machining	<ul style="list-style-type: none"> • Model with less than 10 dimensions - All the dimensions are drawn • Model with more than 10 dimensions: <ul style="list-style-type: none"> • Contour dimensions only • Important dimensions or dimensions with tolerances different than the drawing general tolerances. • High precision parts - All the dimensions.
Sheet metal	<ul style="list-style-type: none"> • Bending dimensions • One drilled hole location dimensions per bend surface • Fasteners/threads definition: type, quantity and fastener's insertion direction

Type of Drawing	Dimensioning method
Metal casting	<ul style="list-style-type: none"> • External dimensions • Notes according to manufacturer's specific requirements • Post-casting machining drawing will have all the machining dimensions.
Plastic casting	<ul style="list-style-type: none"> • External dimensions • Notes
Welds	<ul style="list-style-type: none"> • External dimensions • Parts positioning dimensions (if required). • Post-welding machining drawing will have all the machining dimensions.
Assemblies	If required - post assembly important dimensions

16. Dimension tolerances

Dimension tolerances will be given according to SI 865 (based on ISO R 406 and ISO 286).

17. Geometric tolerances

Geometric tolerances will be given according to SI 1010 (based on ISO DR 1101). The Base planes labeling letters will start with "A" and will continue alphabetically.

18. Surface finish

Surface finish symbols will be given according to SI 780 (Based on ISO DR 1302).

The symbols direction will be given as shown below:

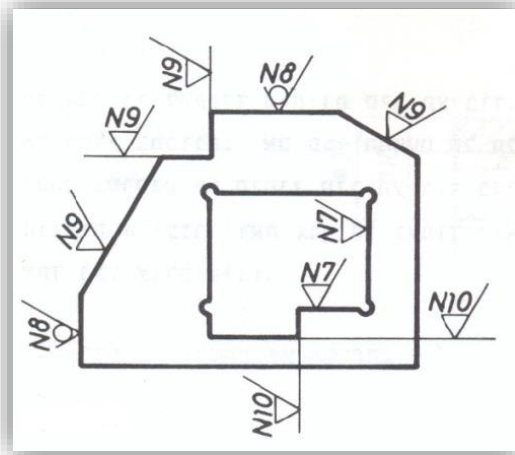

19. Weld symbols

Weld symbols will be used according to SI 1061 (Based on ISO DR 2553).

For the differences between ISO and ANSI standards please see Ziv-Av Engineering - Work procedure W017 - ANSI-AWS Welding symbols.

20. Drawing configuration check-list

(Before submitting drawings for approval or to client)

It should be noted that the following list does not check for design errors or that the right tolerances were given (these checks are to be performed by the designer), but it can be used as a drawing configuration checklist, that will prevent manufacturing errors (due to incorrect drawings) and it will save time for the official drawing inspector (Project manager / Team leader).

20.1. General

- The views scale is a standard one and is the same one as the one in the title block.
- In drawings with extremely large scale, there is a 1:1 scale view (not an isometric one) on the side of the sheet.
- All the title block fields are filled.

- The Notes area is well organized including the correct references in the title block to material and finish notes.
- The drawing sheet is clean - all the dimensions, balloons and revision triangles do not overlap one another or the model lines.
- The views/section views labels - start with "A" and continue alphabetically.
- Tangent lines are only in isometric view - and drawn in thin lines.
- All required symmetry lines and centerlines are drawn.
- For dimensioned drilled holes/threads: all the drilled holes have centerlines, with grouping option.
- No dimensions for hidden lines.
- For large parts with small scale: the external dimensions are drawn from external body lines.
- All the part details are presented at least in one view.
- For standard raw materials such as profiles - there are no sizes written in the material field in the notes or title block.
- All the non relevant notes at the Note area are cleared.
- The ECO table last revision and the title block revision are the same.
- All the threads marks are drawn.
- There are no chain dimensions.
- The surface finish is defined (normally N5-N9).
- Section view lines and Broken-out section views are linked to vertex point, and do not "float".

20.2. Reduced dimensions drawings

20.2.1. Machined part

(For a model with less than 10 dimensions - All the dimensions are given)

- External part dimensions.
- Important features dimensions: drilled holes, planes.
- Important features tolerances: both dimensions and geometric tolerances.

20.2.2. Single sheet metal part

- General contour dimensions of the bent part.
- Check all bends' dimensions (length) in the part, prior to eliminating similar dimensions in the drawing.
- Bends' dimensions (length + angle for angles different than 90°).
- Part thickness + "STOCK" note.
- Dimensions between important drilled holes + diameter dimension of important drilled holes.
- Dimensions of post-bending machining: drilled holes' chamfer, holes drilled through bends, etc.
- Isometric view of the assembly + BOM (for parts with self clinching fasteners).

20.3. Fully dimensioned drawings

- 20.3.1. Same checklist as in reduced dimensions drawings
- 20.3.2. All the part features are dimensioned.

20.4. Welds drawings

- 20.4.1. BOM table positioned above the title block. The BOM table titles are at the bottom side.
- 20.4.2. All parts have balloons and they are all aligned.
- 20.4.3. Overall dimensions of assembly after welding.
- 20.4.4. Important dimensions after welding.
- 20.4.5. All parts have weld symbols.

20.5. Assembly drawings

- 20.5.1. All views have the same configuration, unless decided otherwise.
- 20.5.2. All views are linked to the BOM.

- 20.5.3. BOM table positioned above the title block. The BOM table titles are at the bottom side.
- 20.5.4. All parts have balloons and they are all aligned.
- 20.5.5. All the parts are visible.
- 20.5.6. In exploded view there are exploded lines between parts.
- 20.5.7. Section views do not cut fasteners, pins ect.
- 20.5.8. Overall and important assembly dimensions are given.